

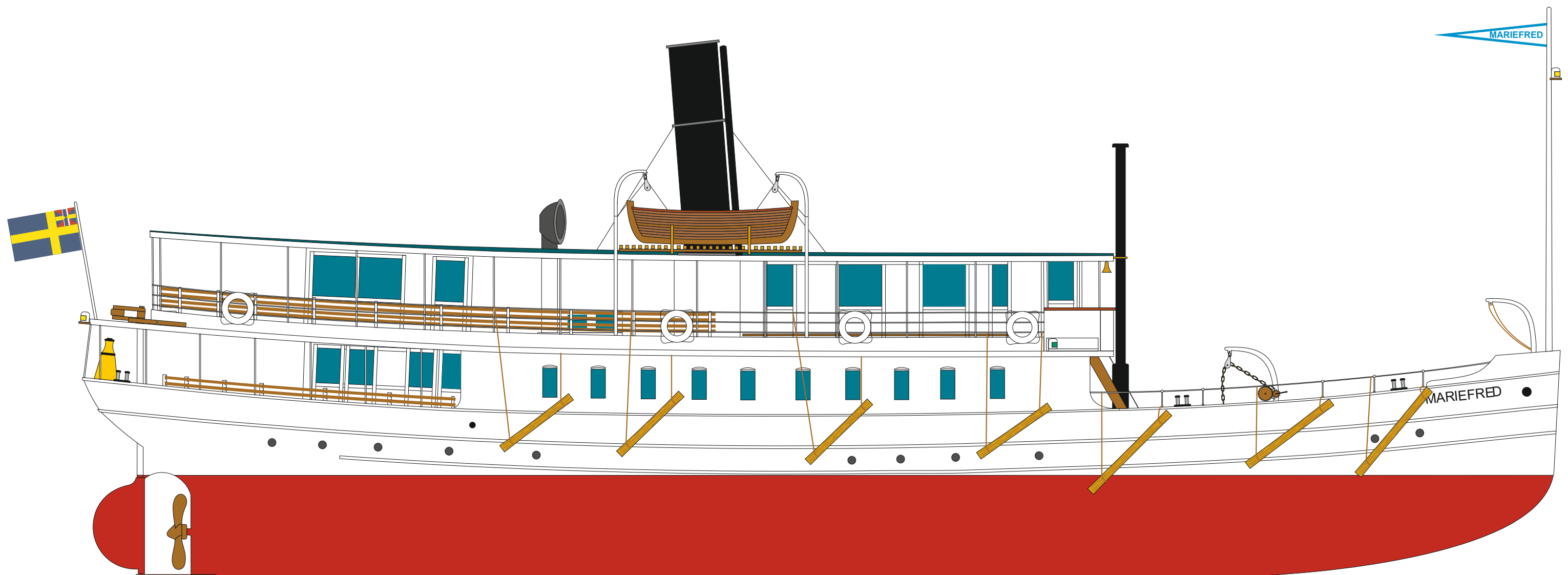







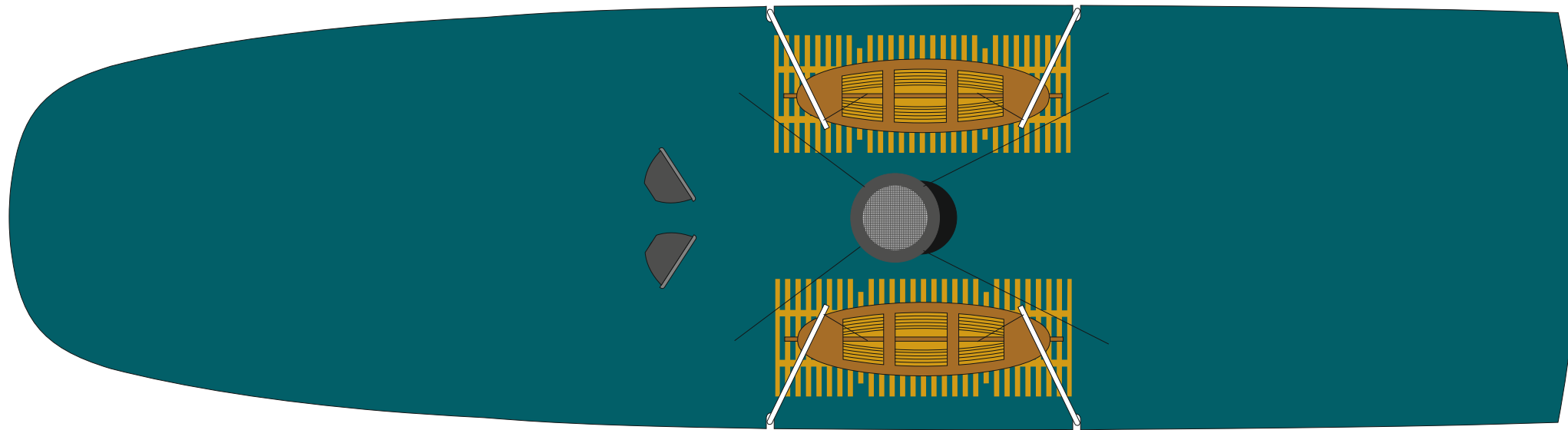

# MARIEFRED 1:32

	White
	Black
	Red
	Gray
	Brown
	Green
	Gold



# MARIEFRED 1:32



-  White
-  Black
-  Red
-  Gray
-  Brown
-  Green
-  Gold

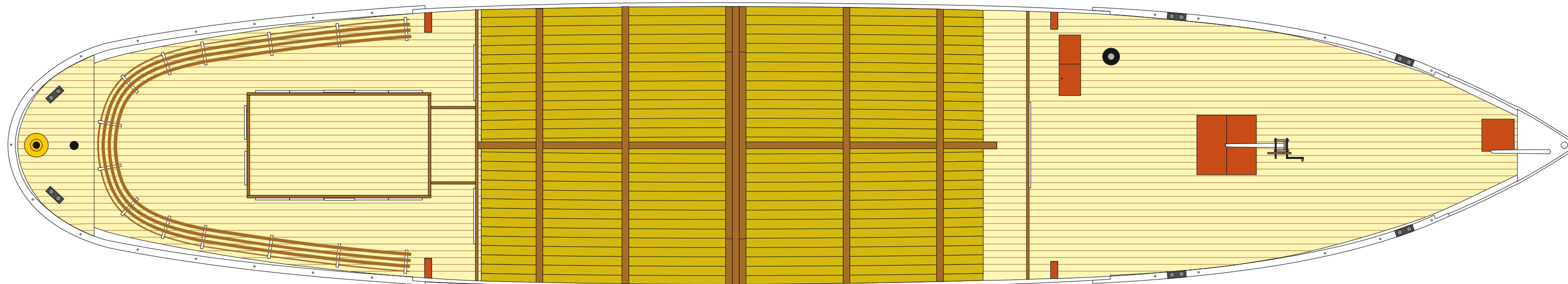
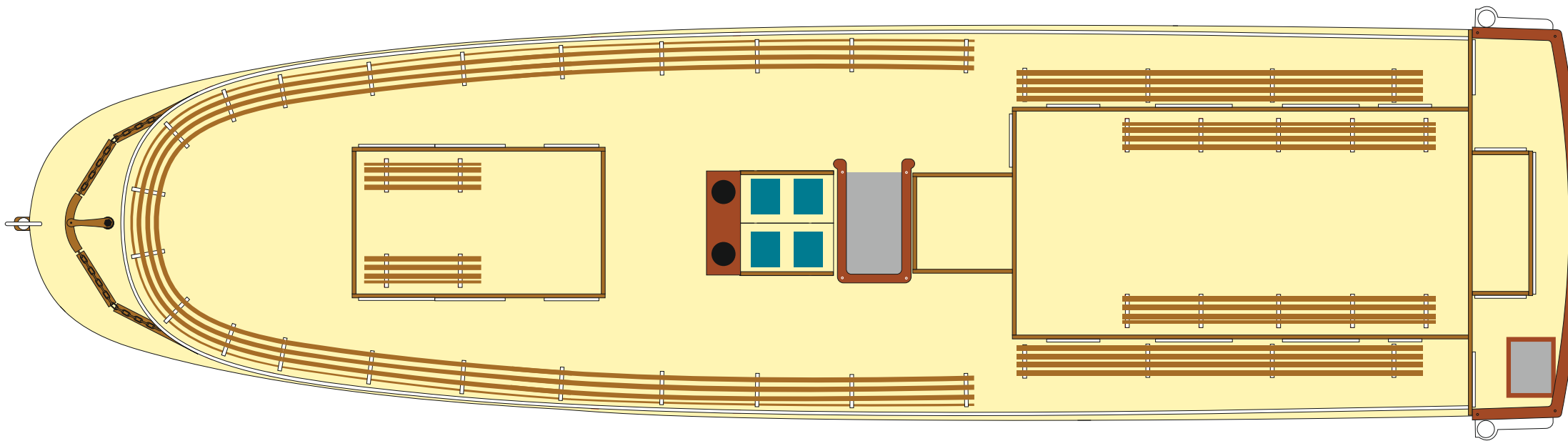

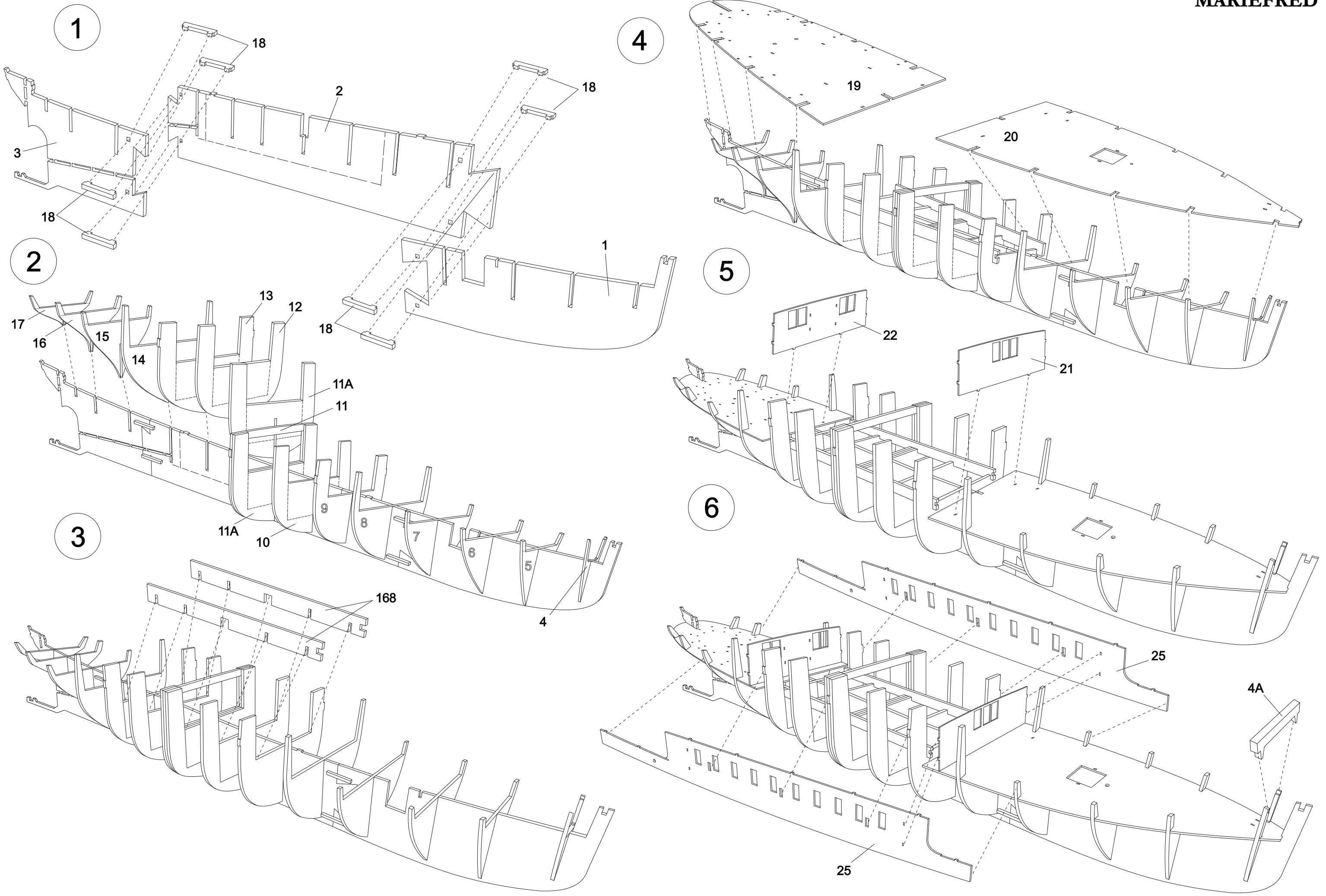

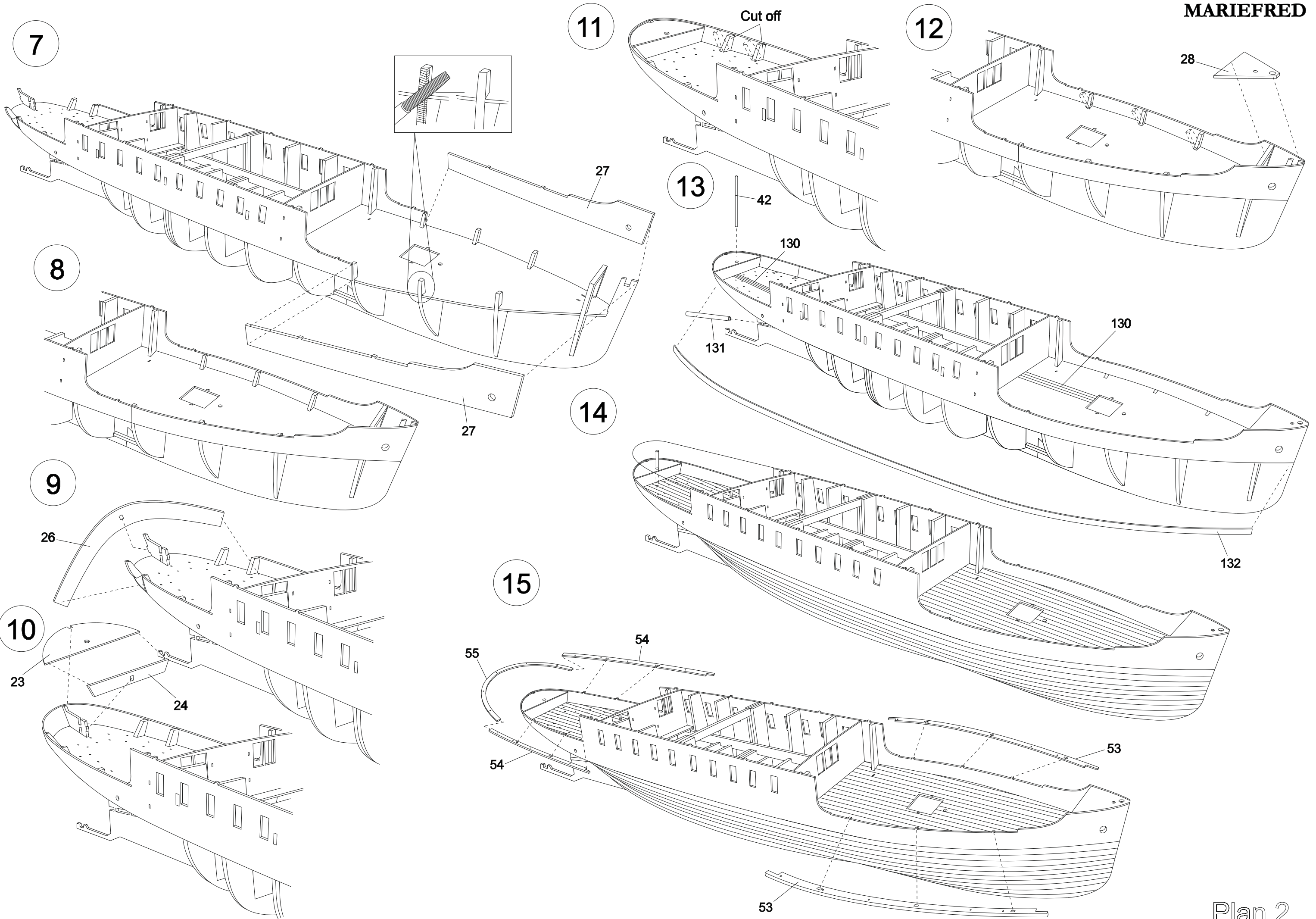



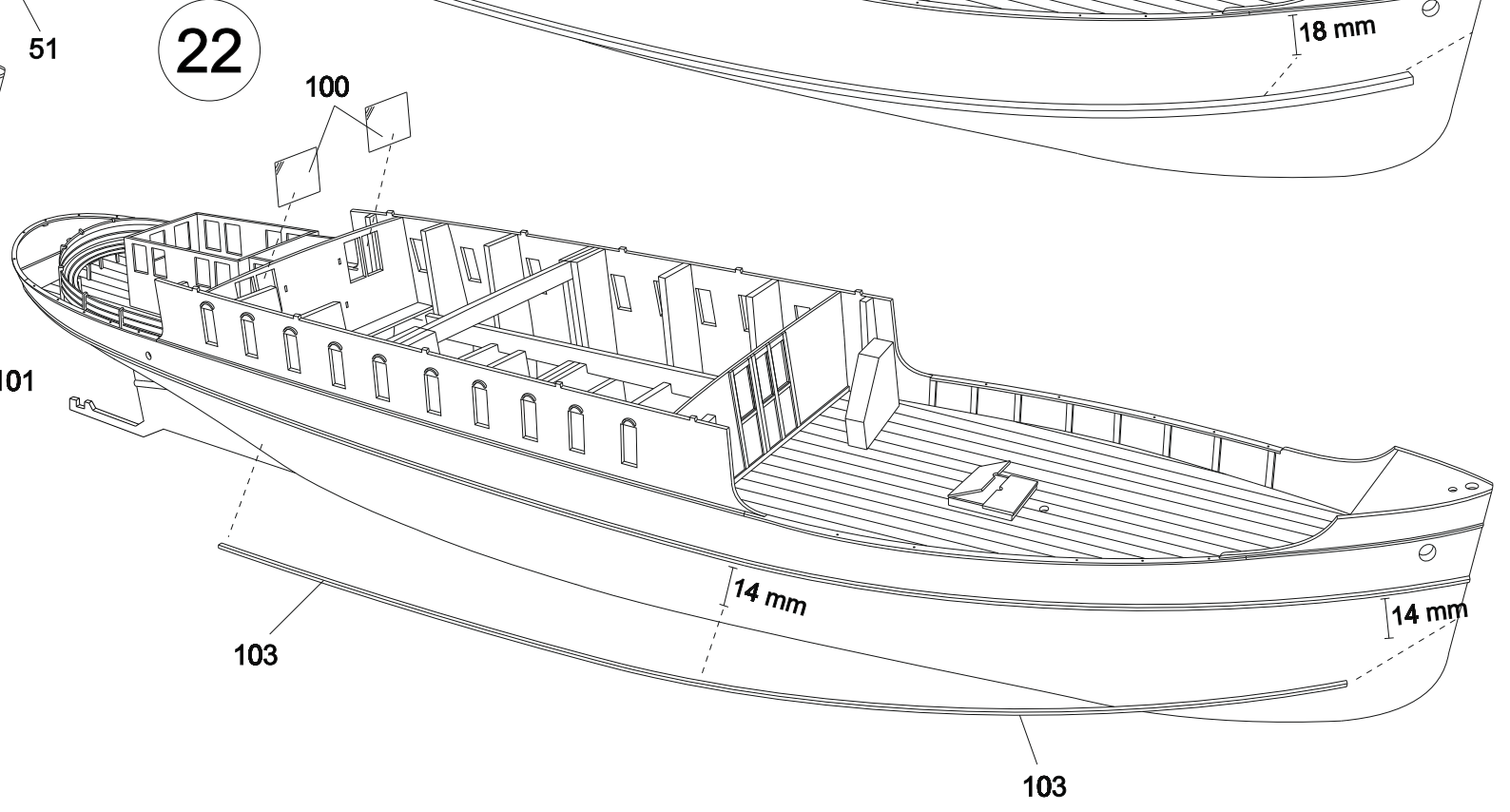
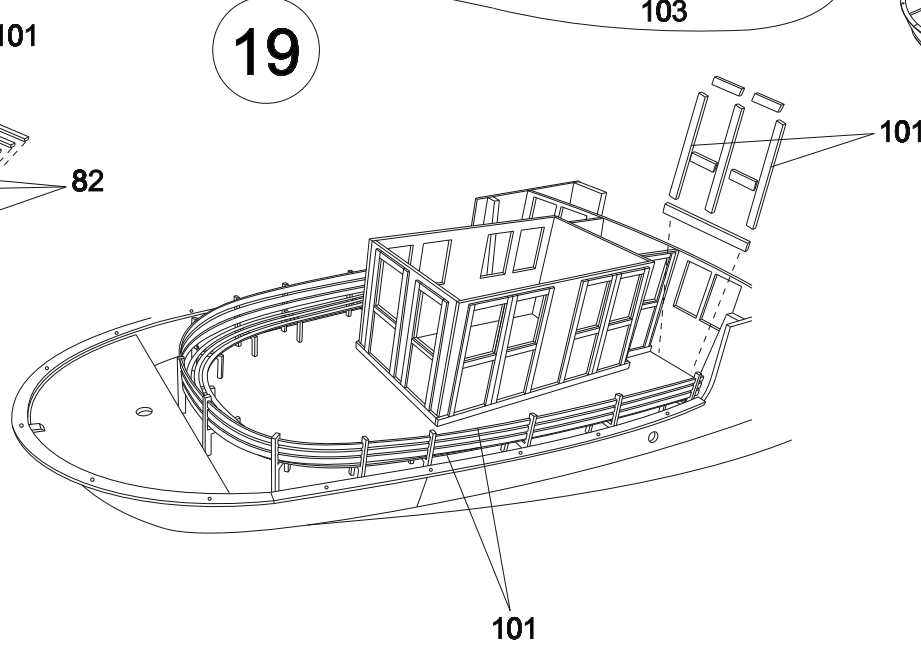
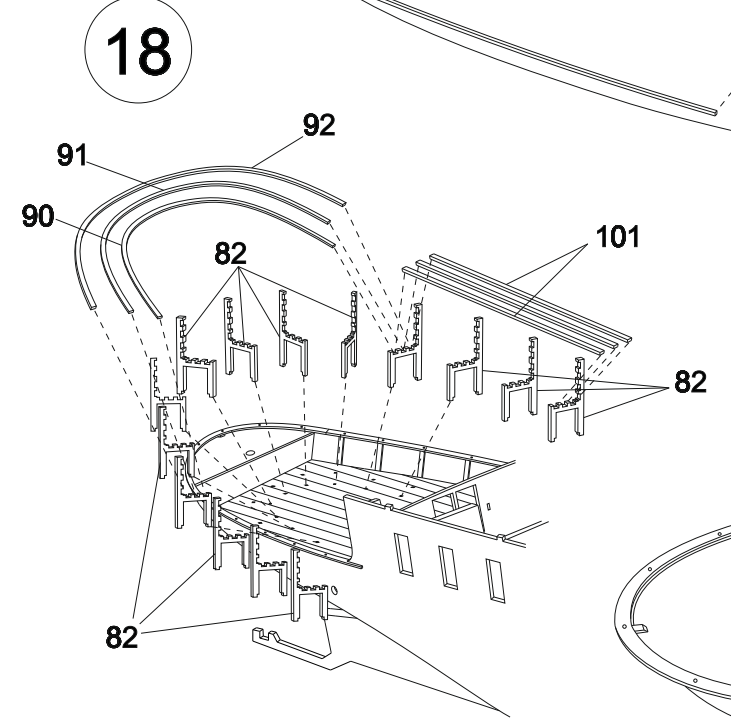
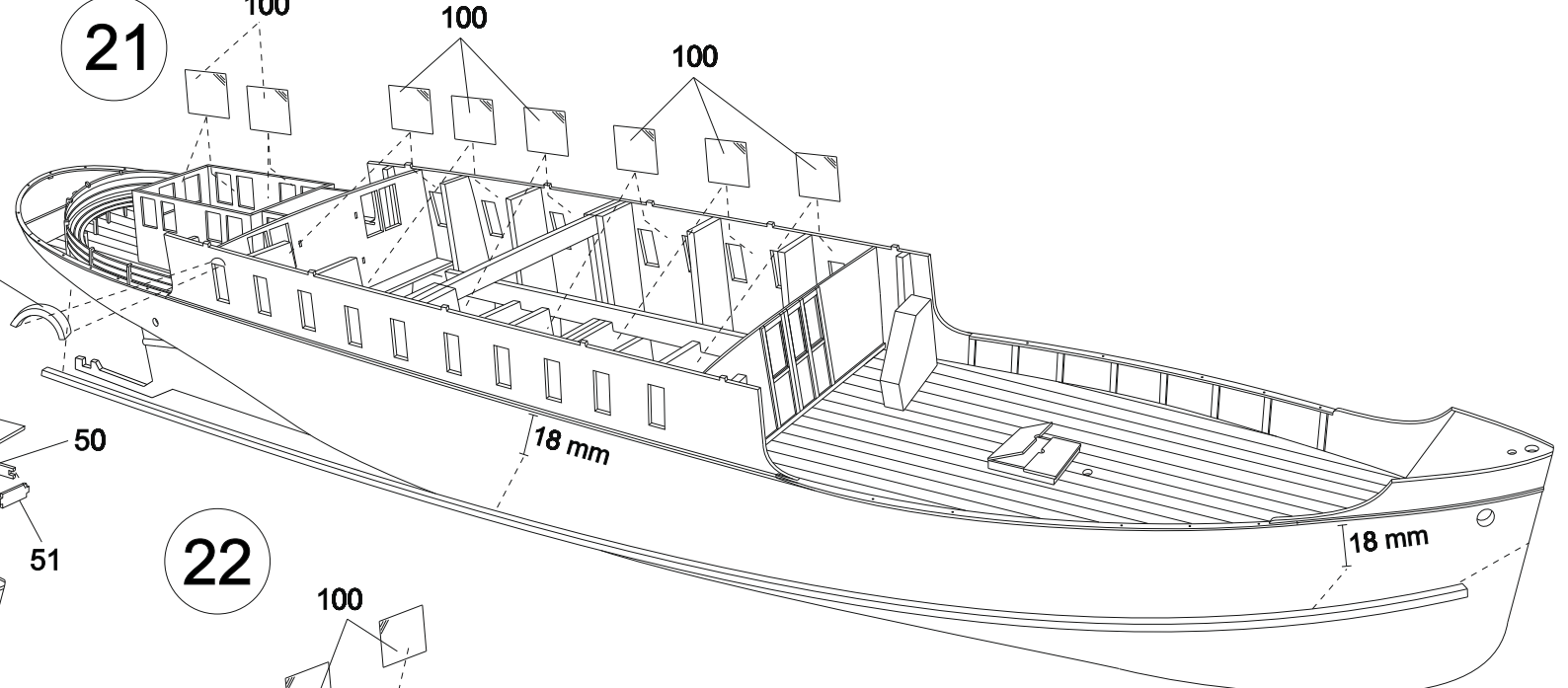
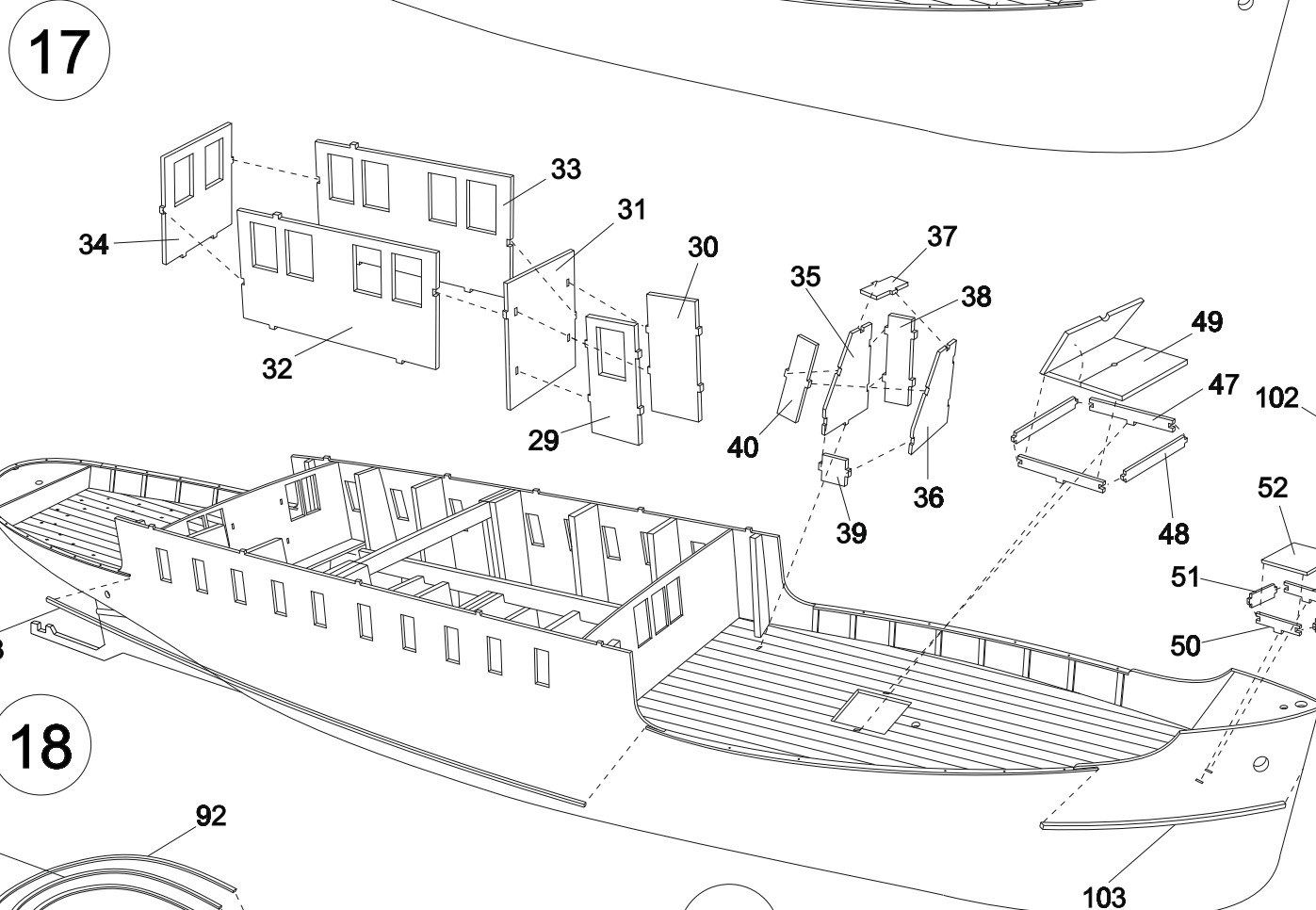
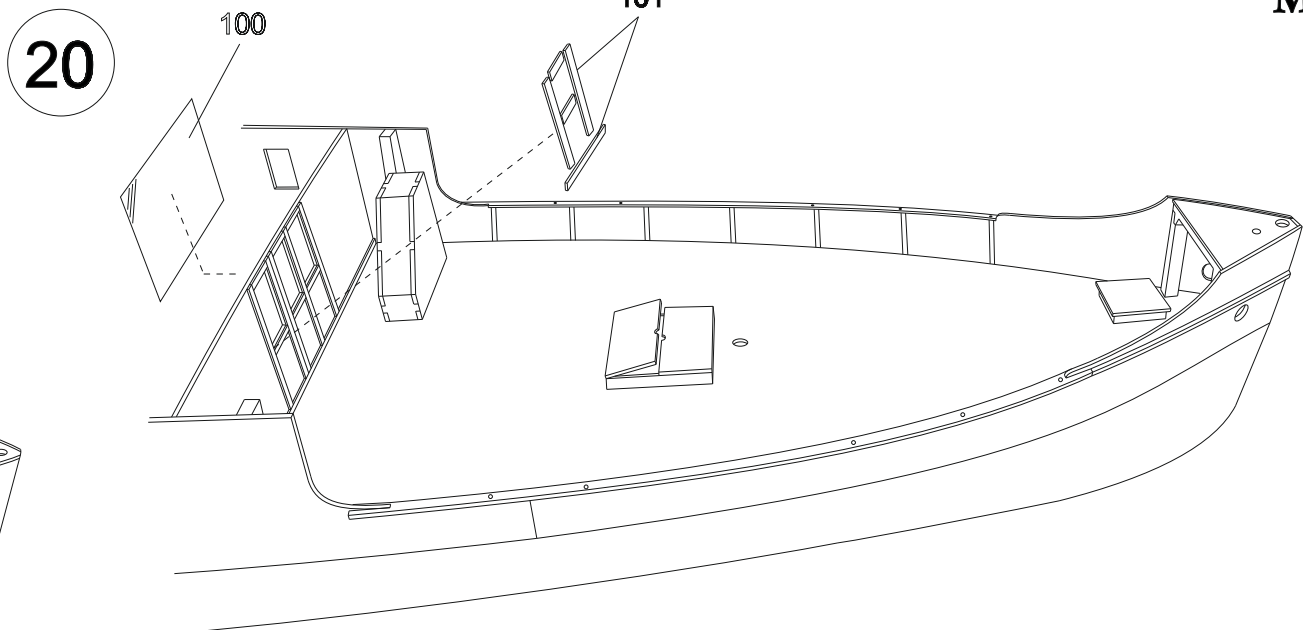
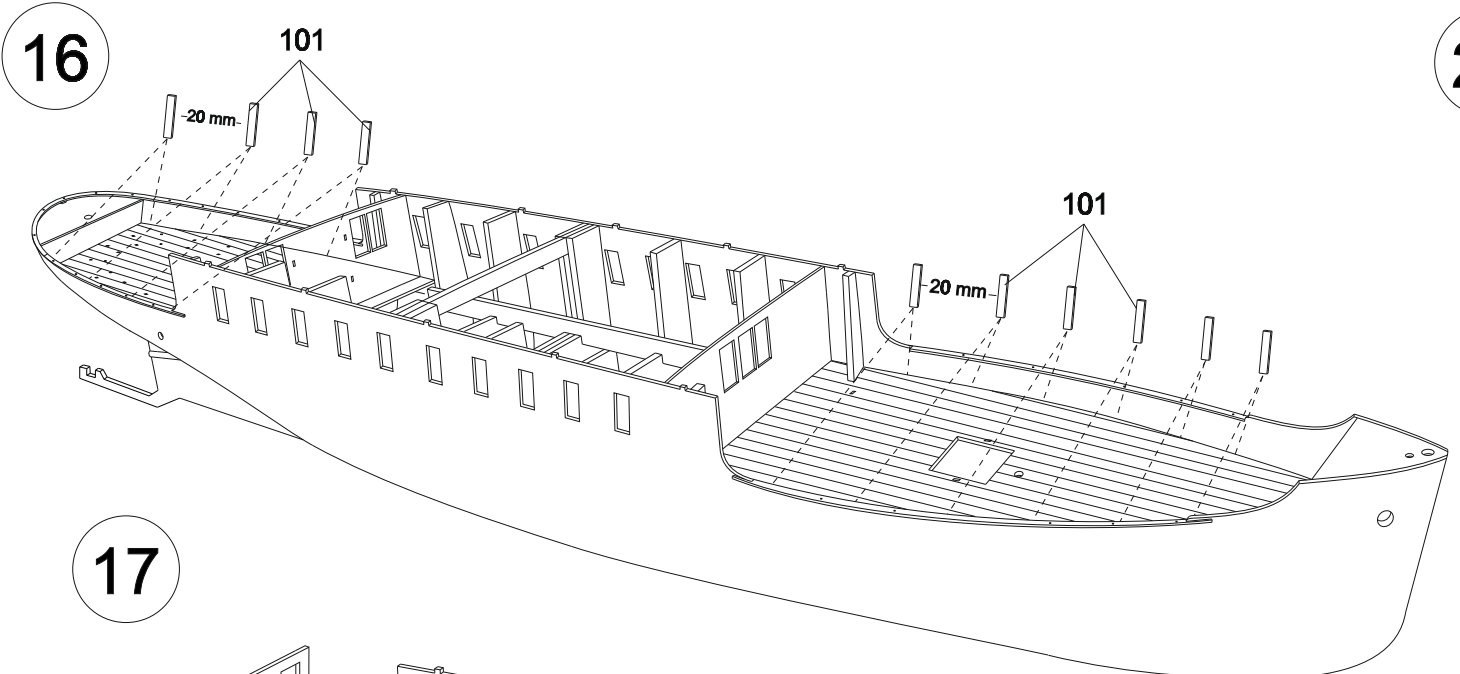

23

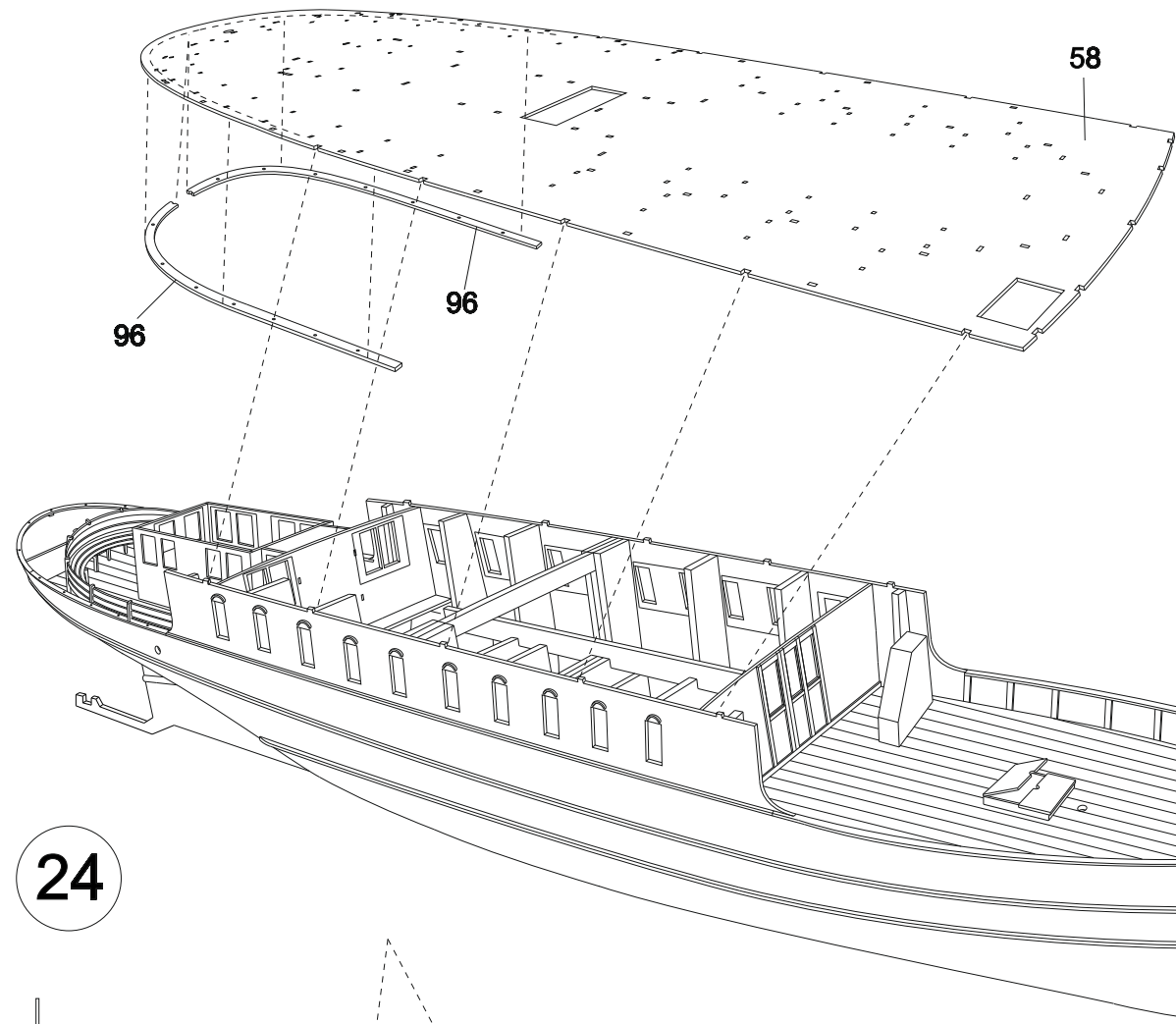

25

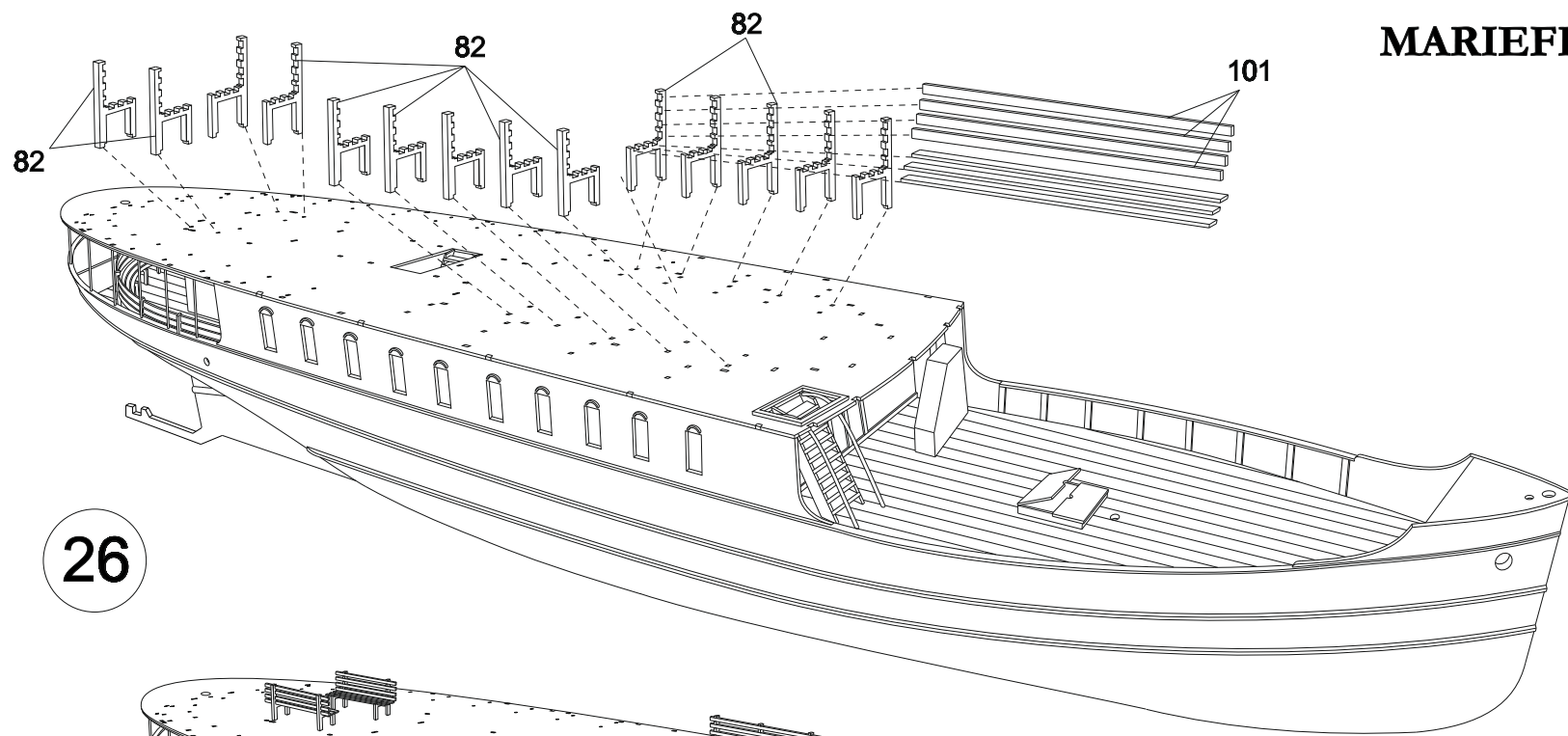

26

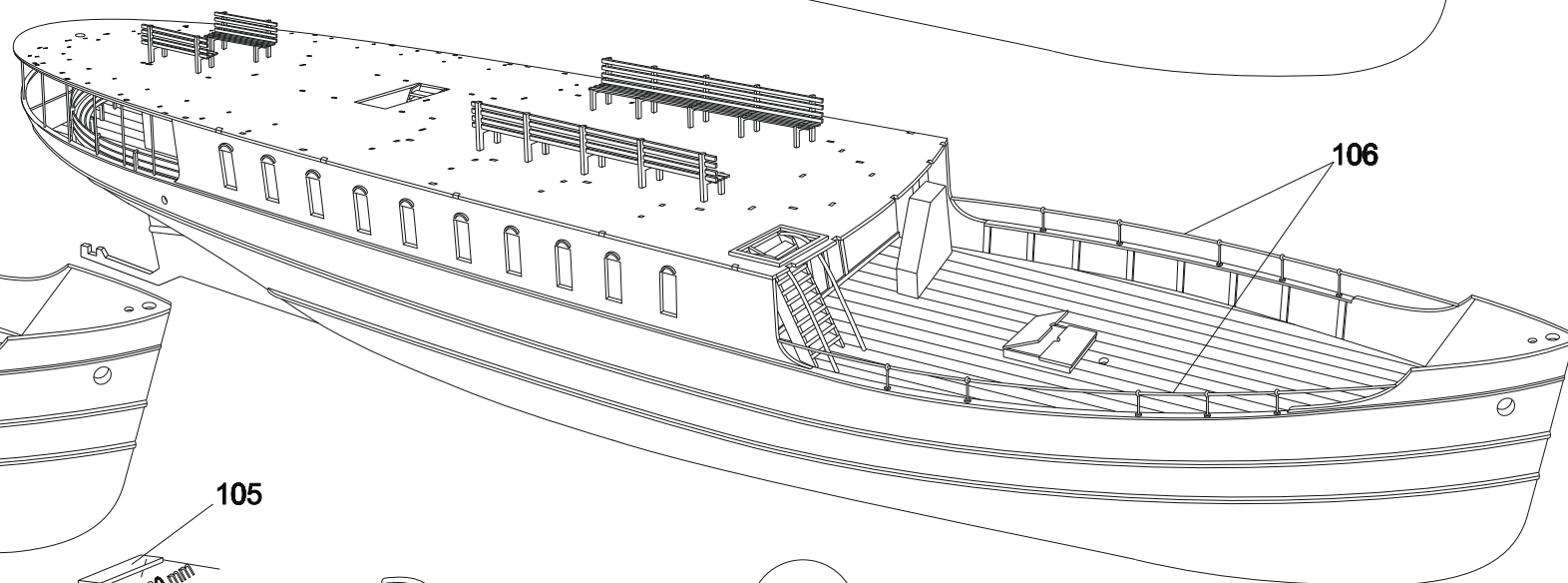

24

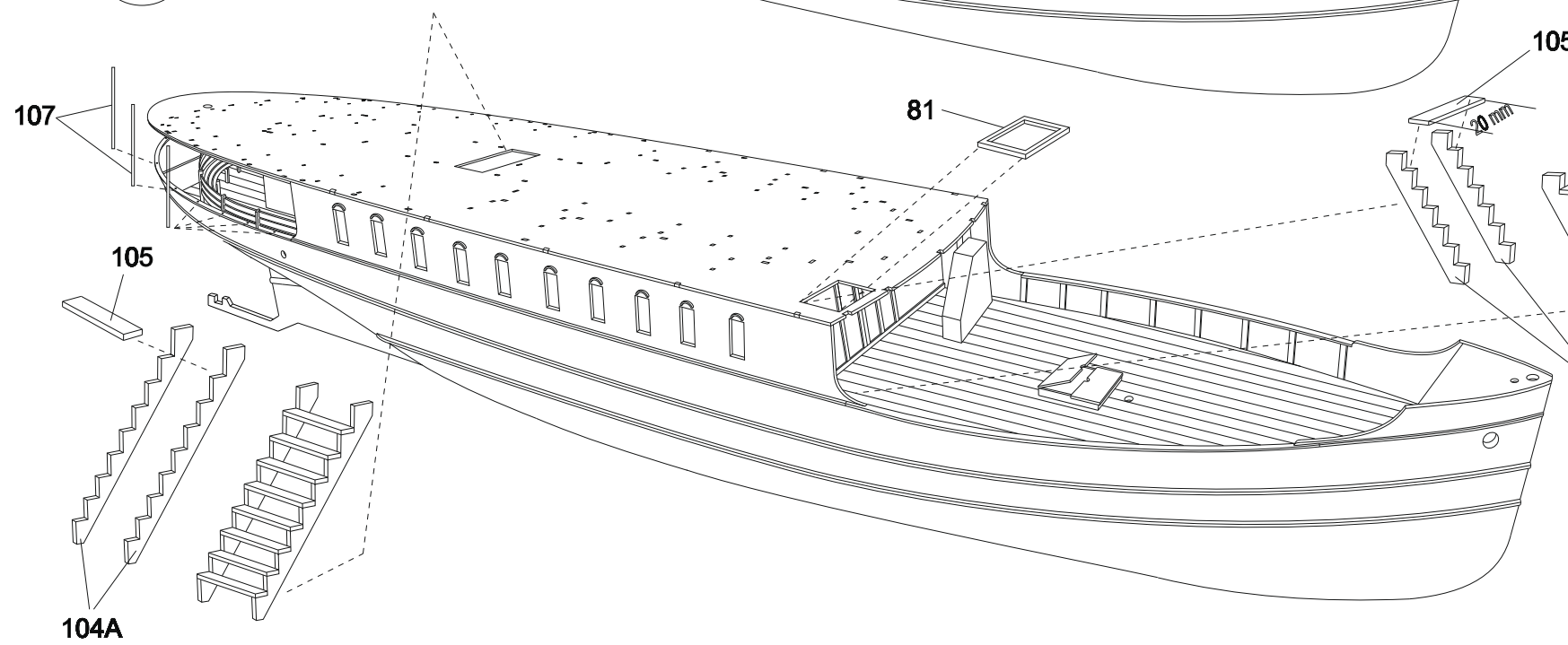

27

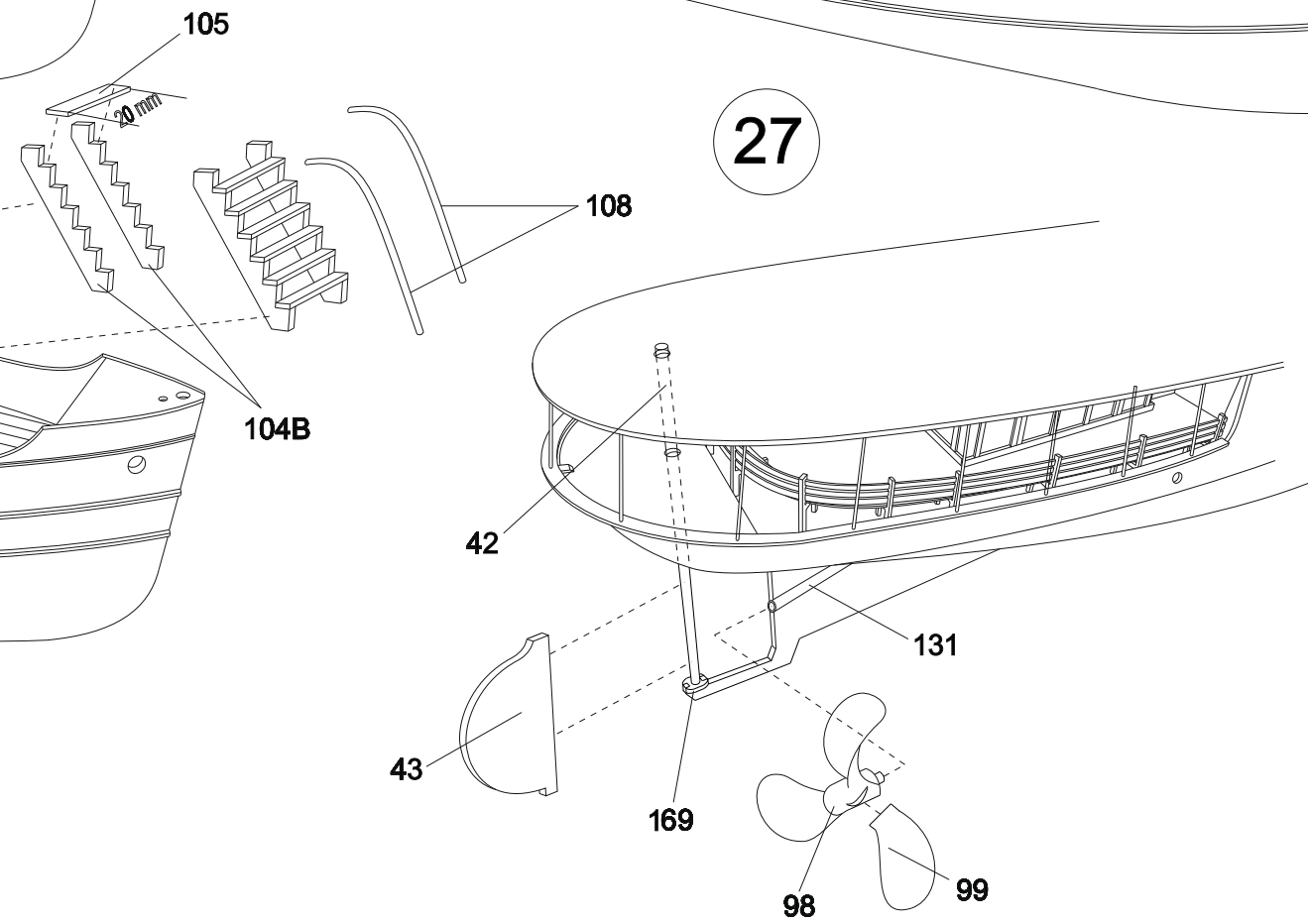



28

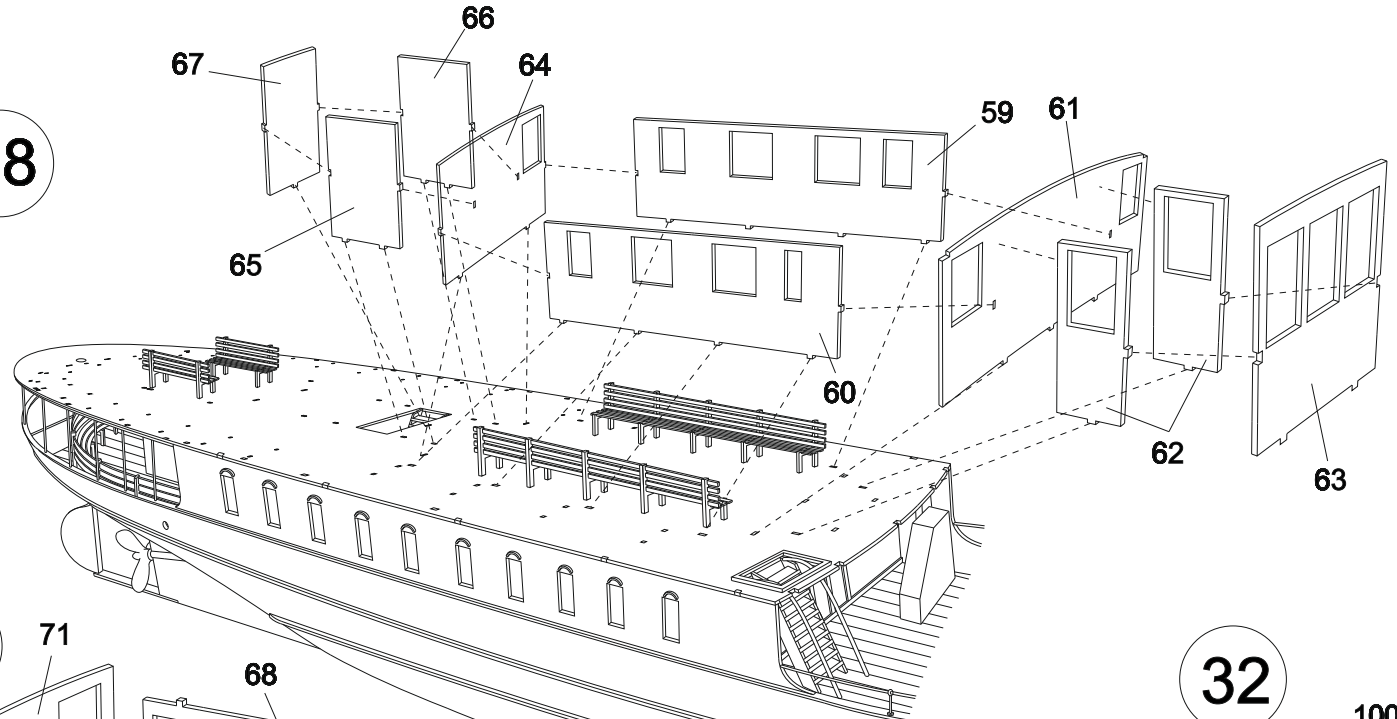

31

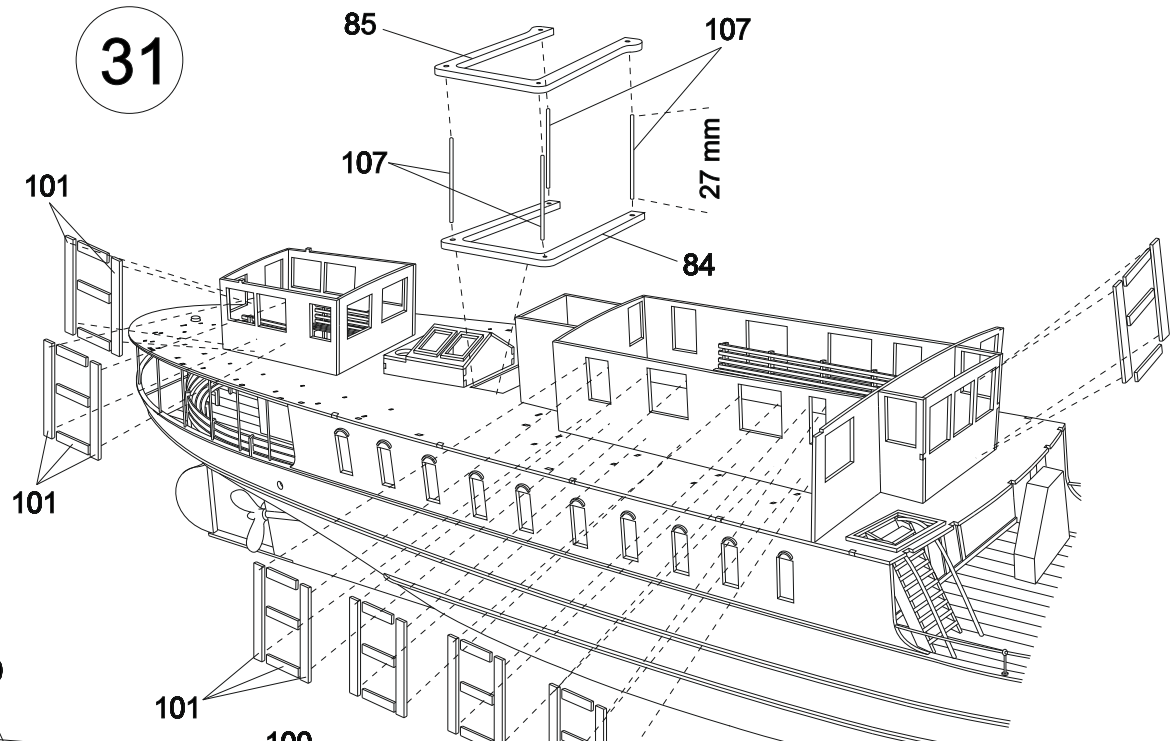

29

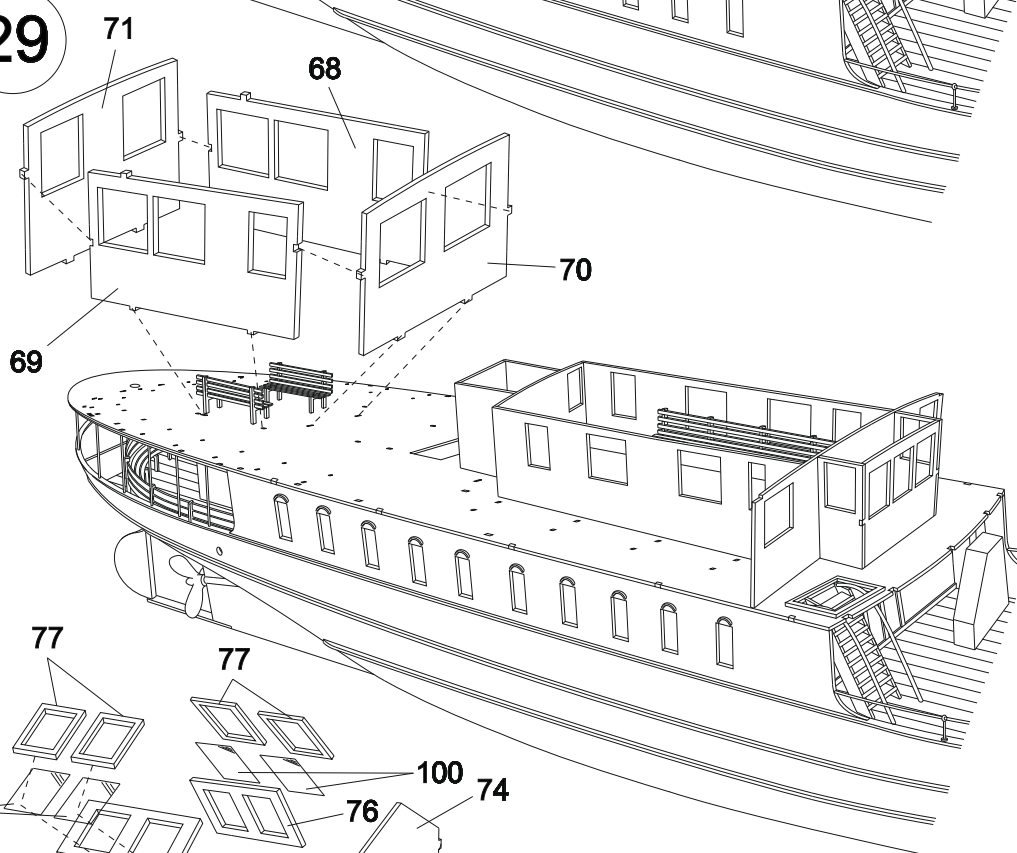

32

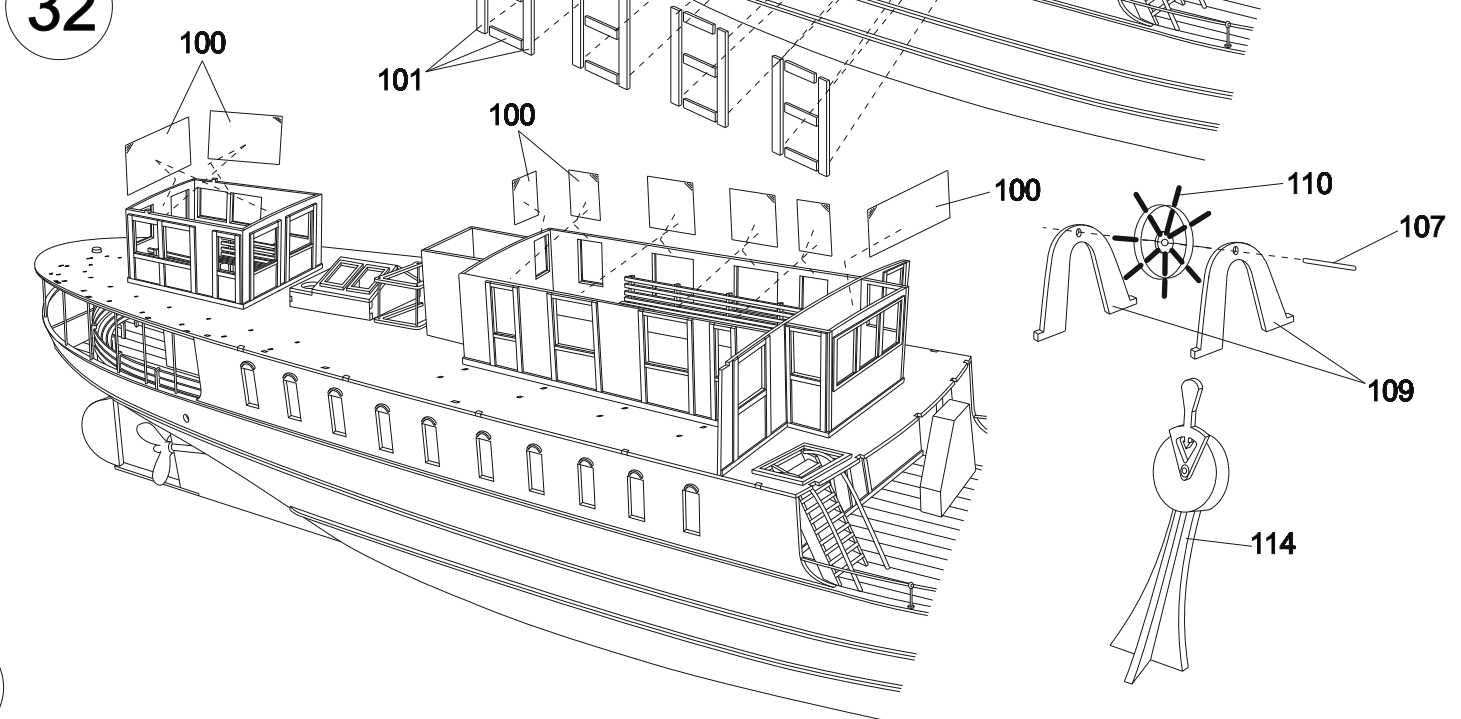

30

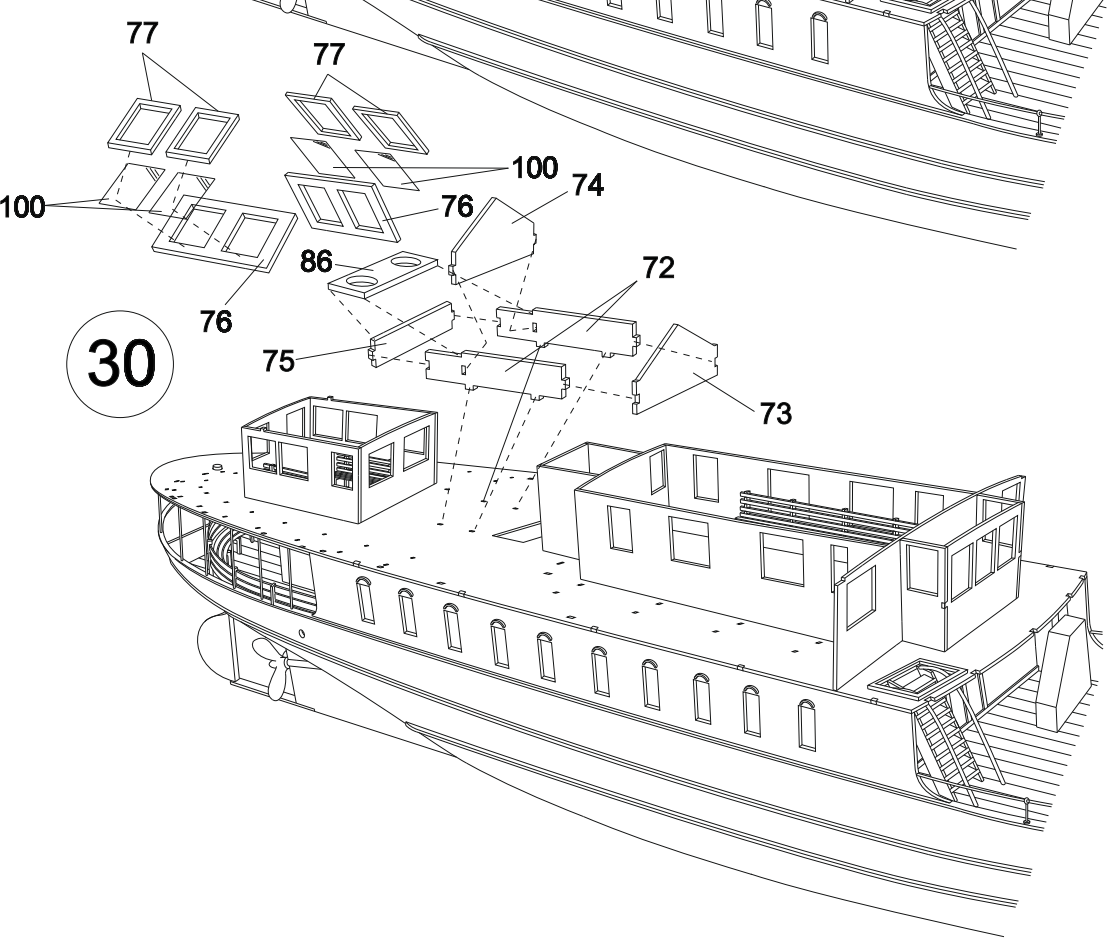

33

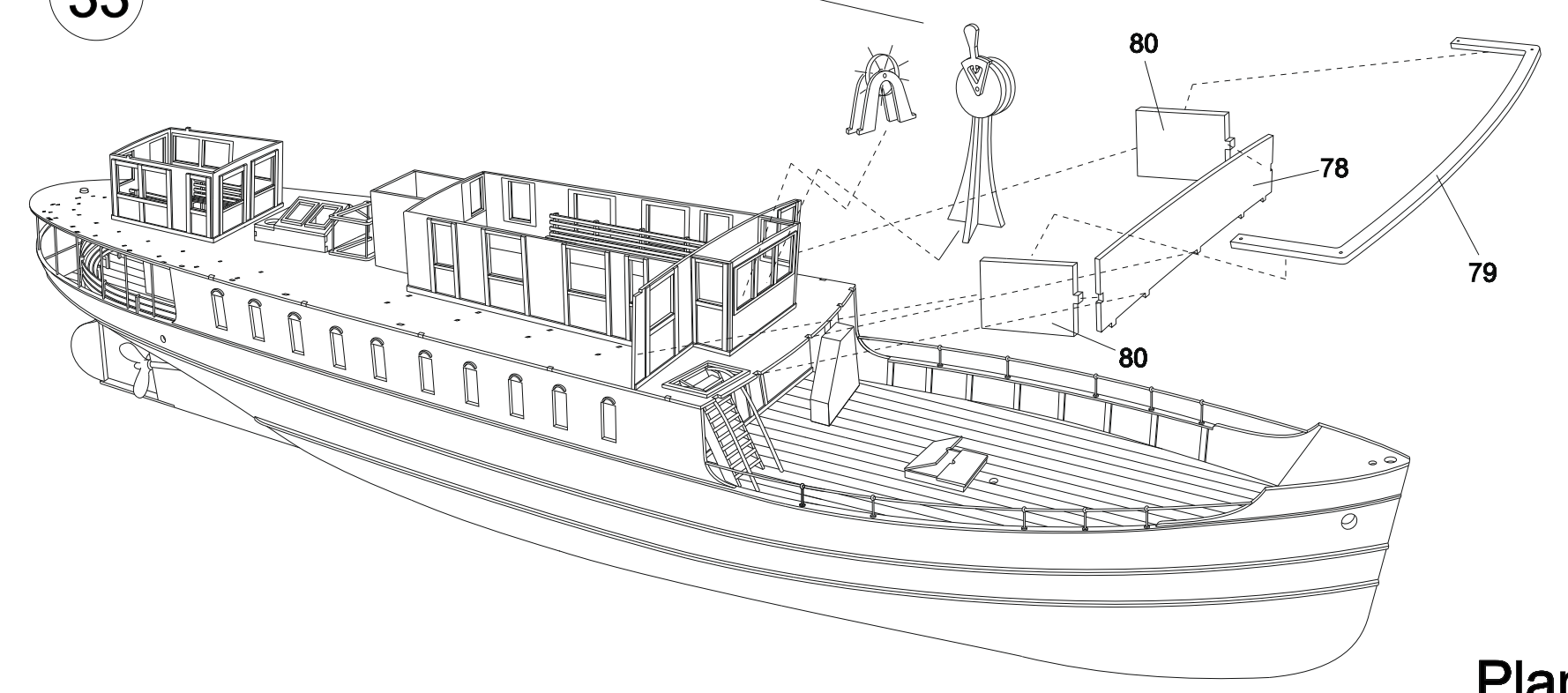



34

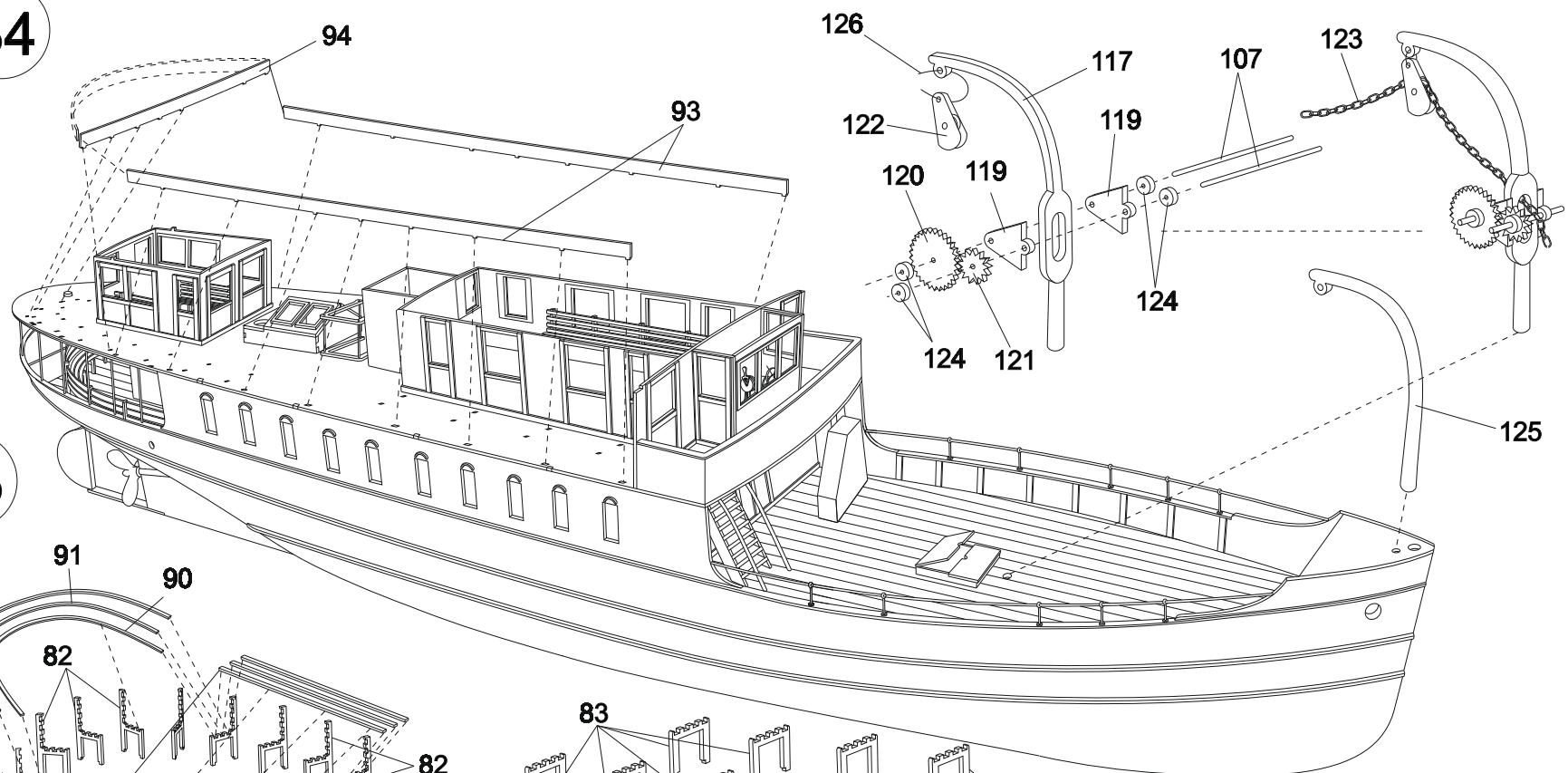

35

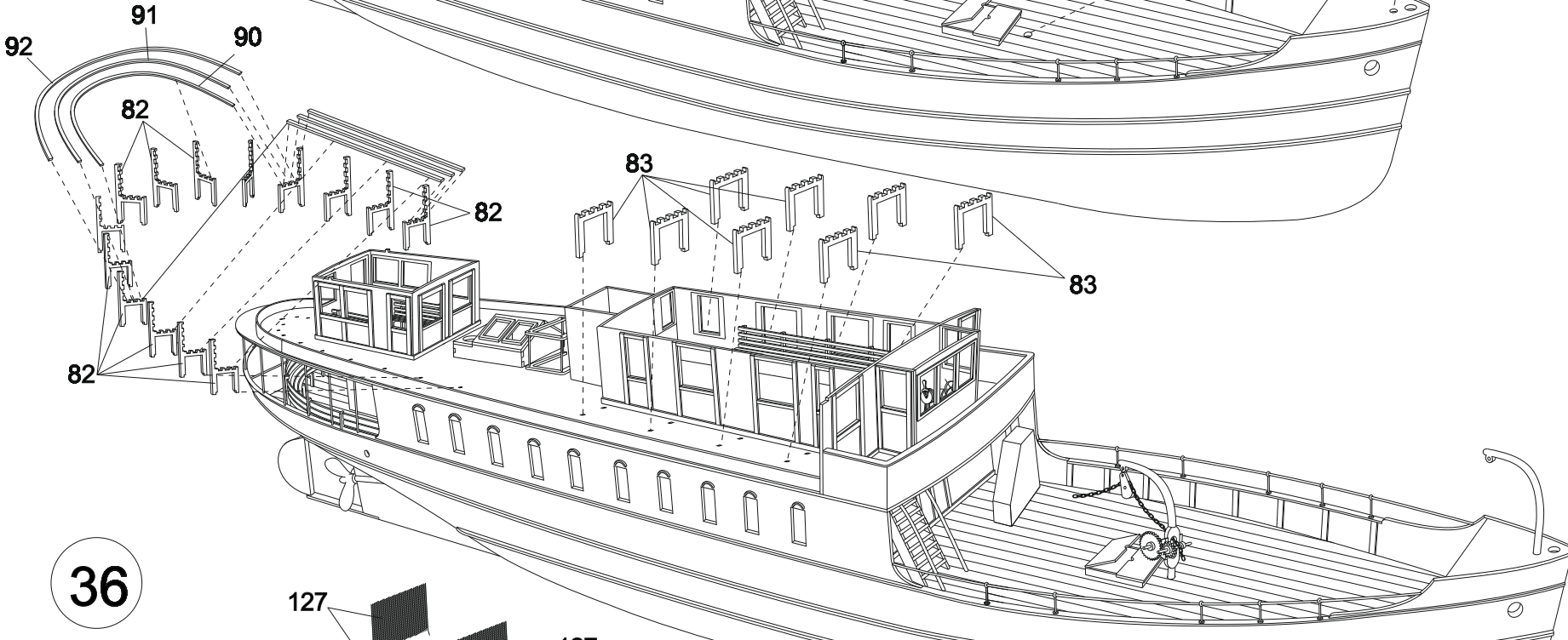

36

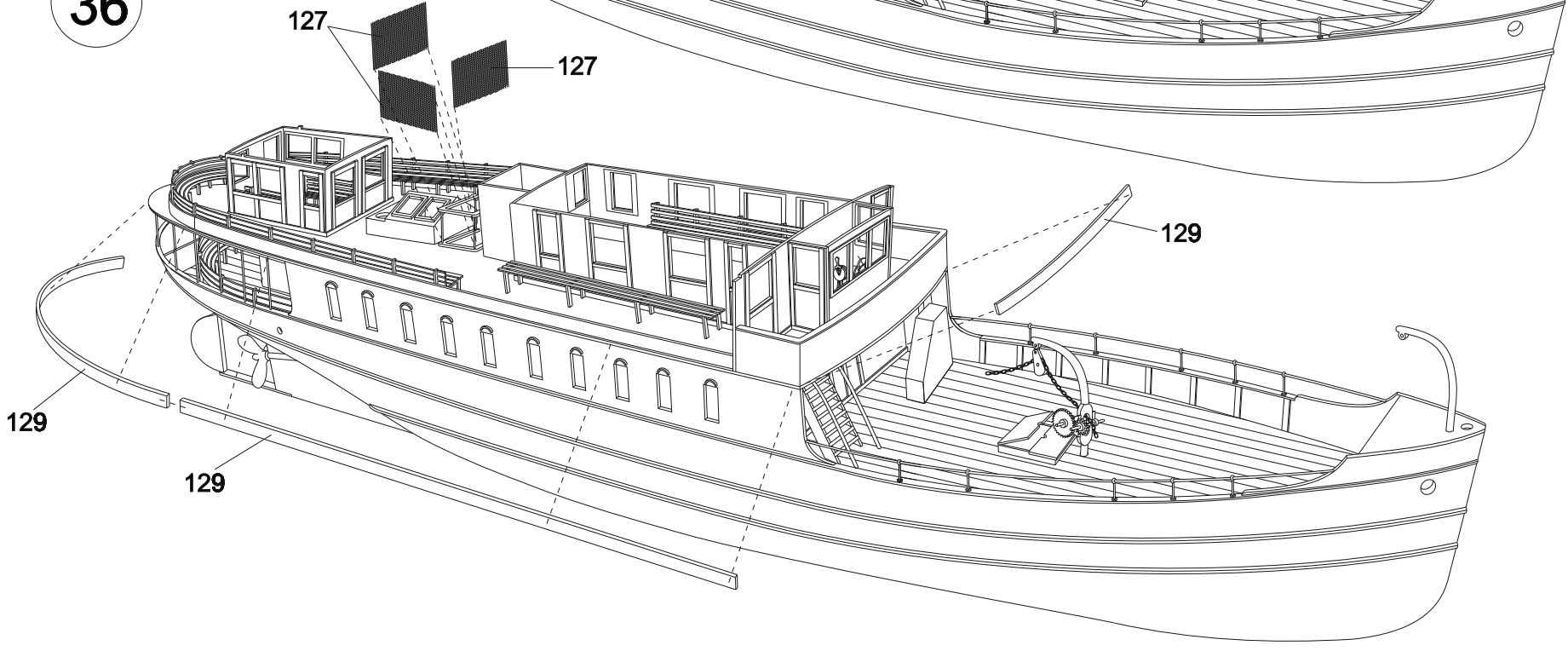

37

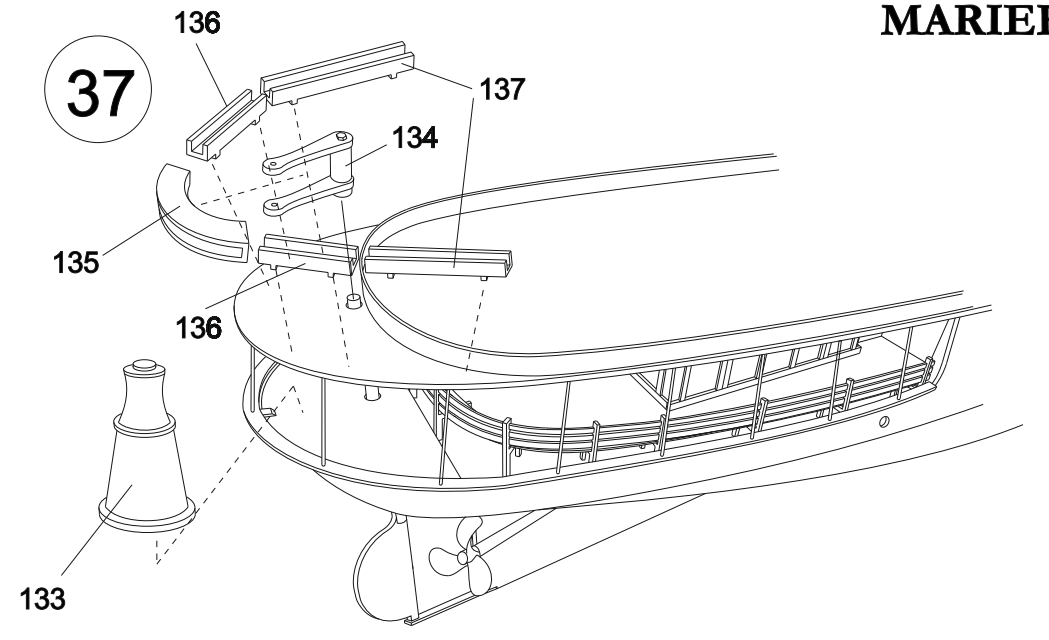

38

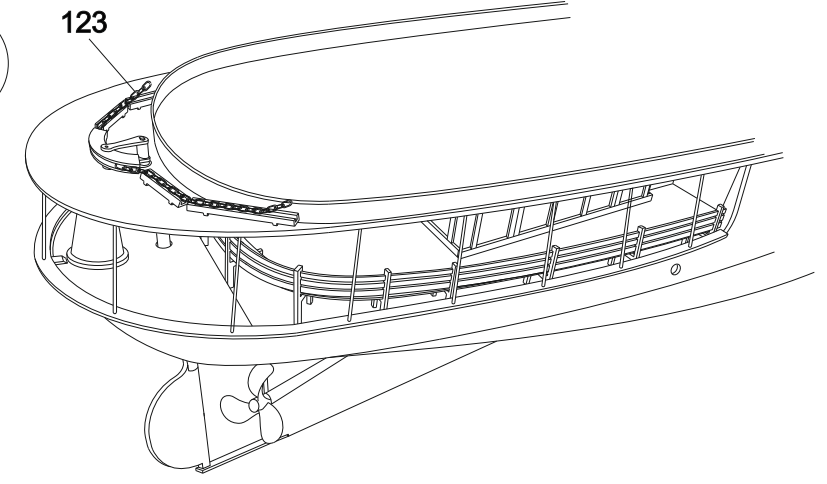

39

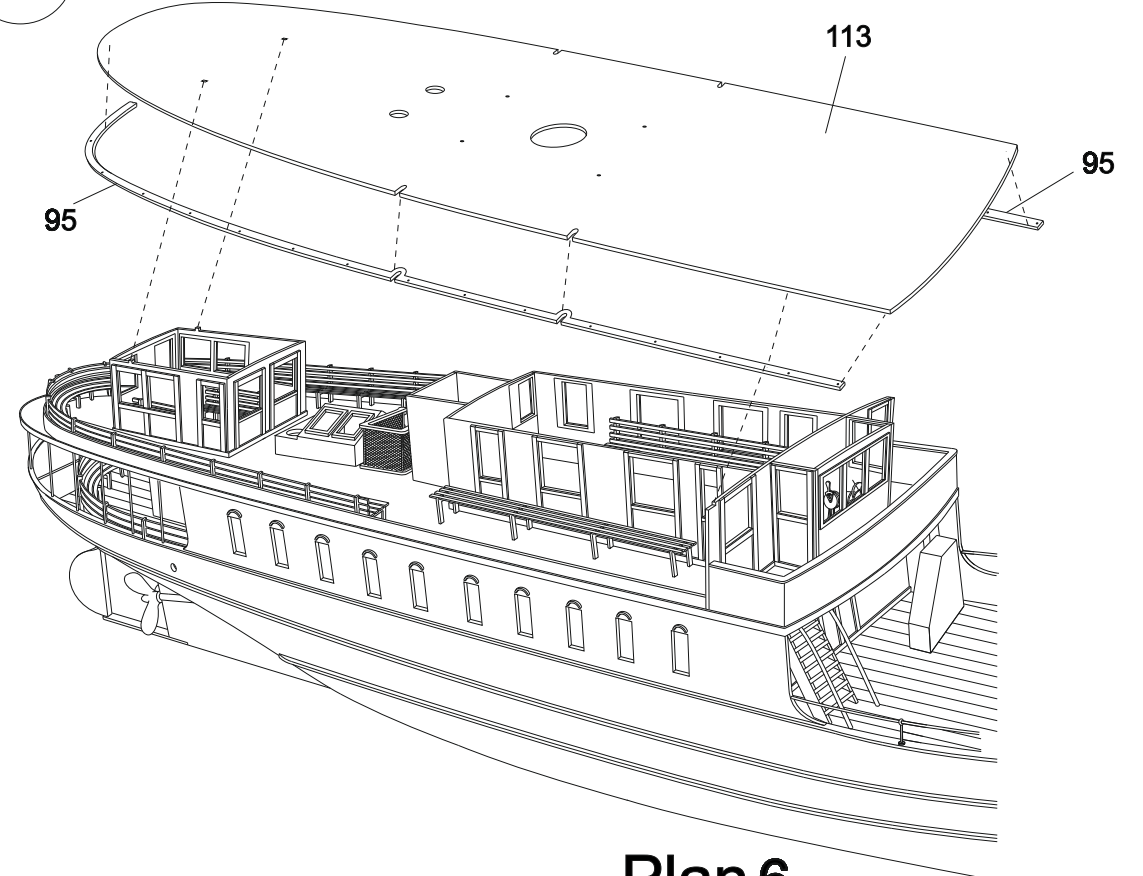



40

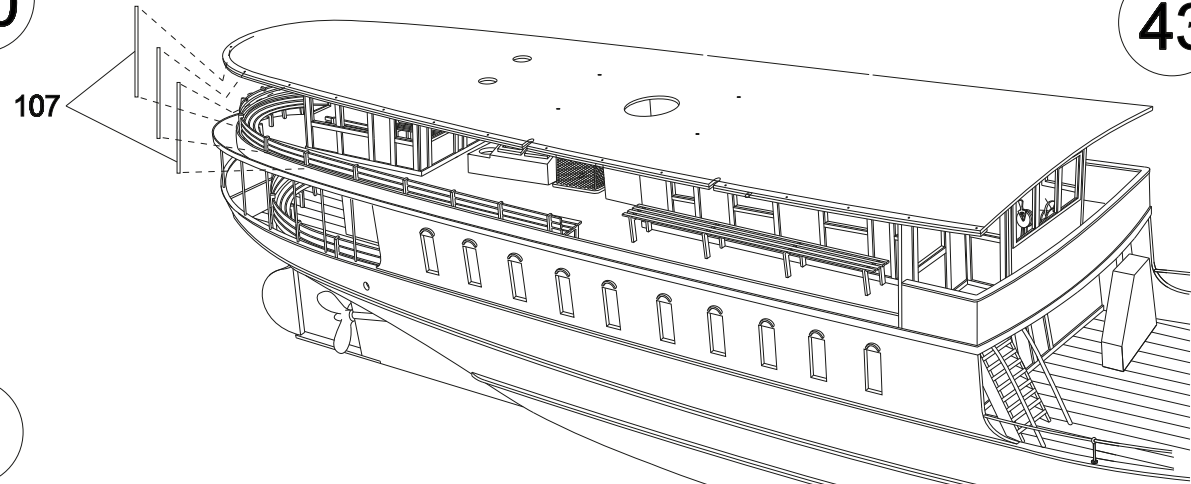

43

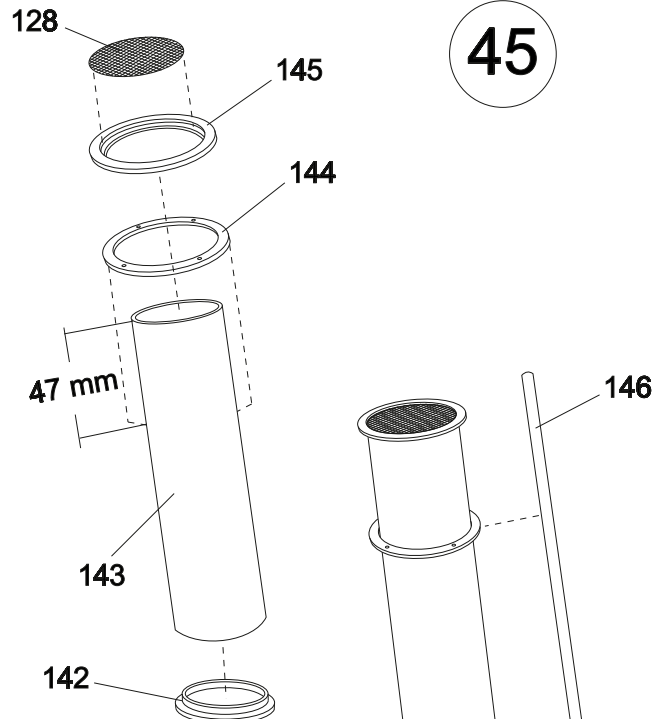

45

2x

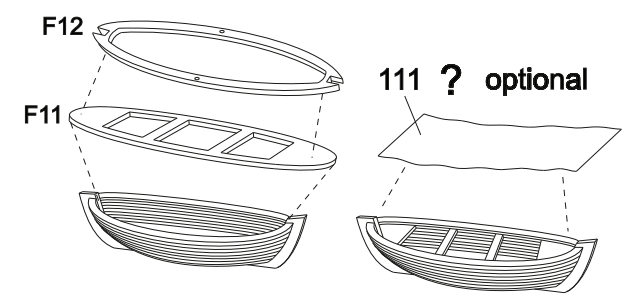
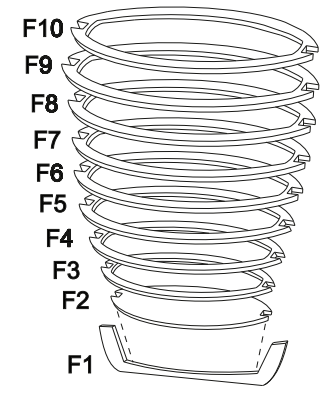

41

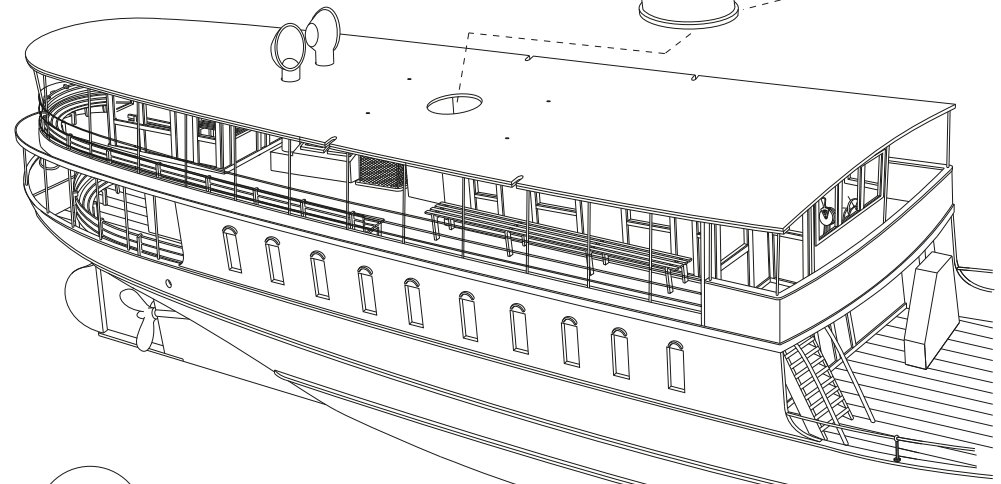
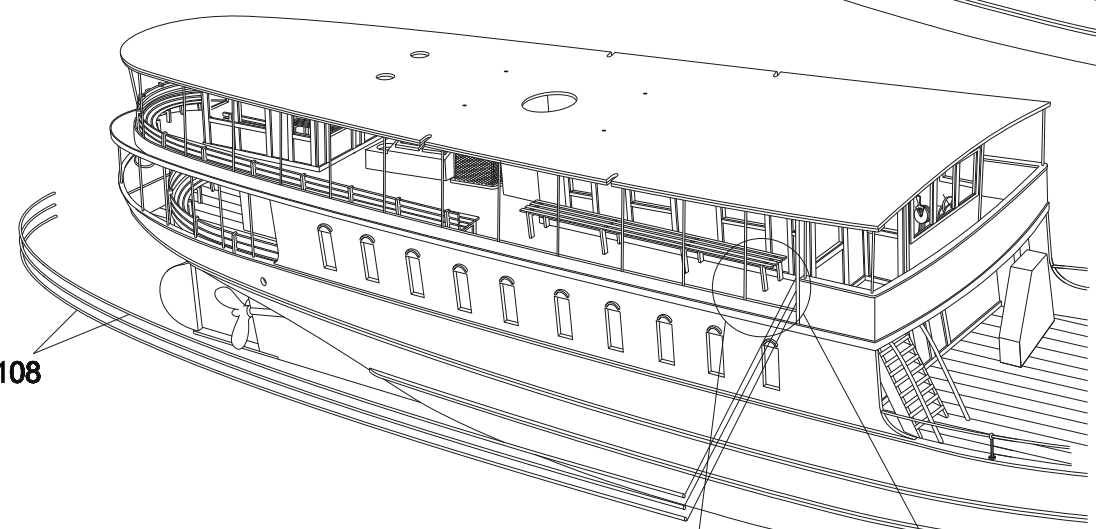

46

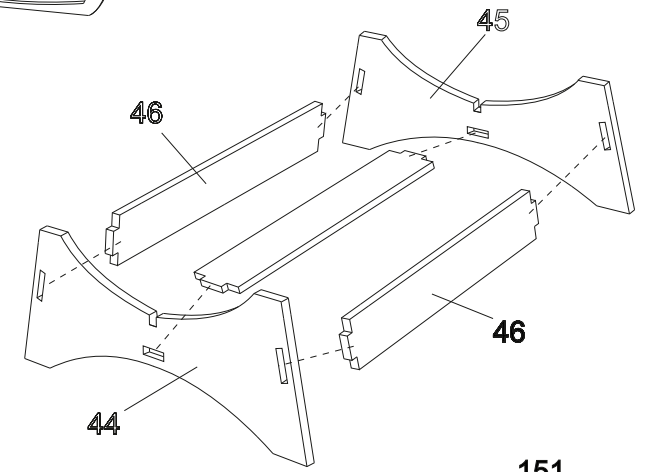

42

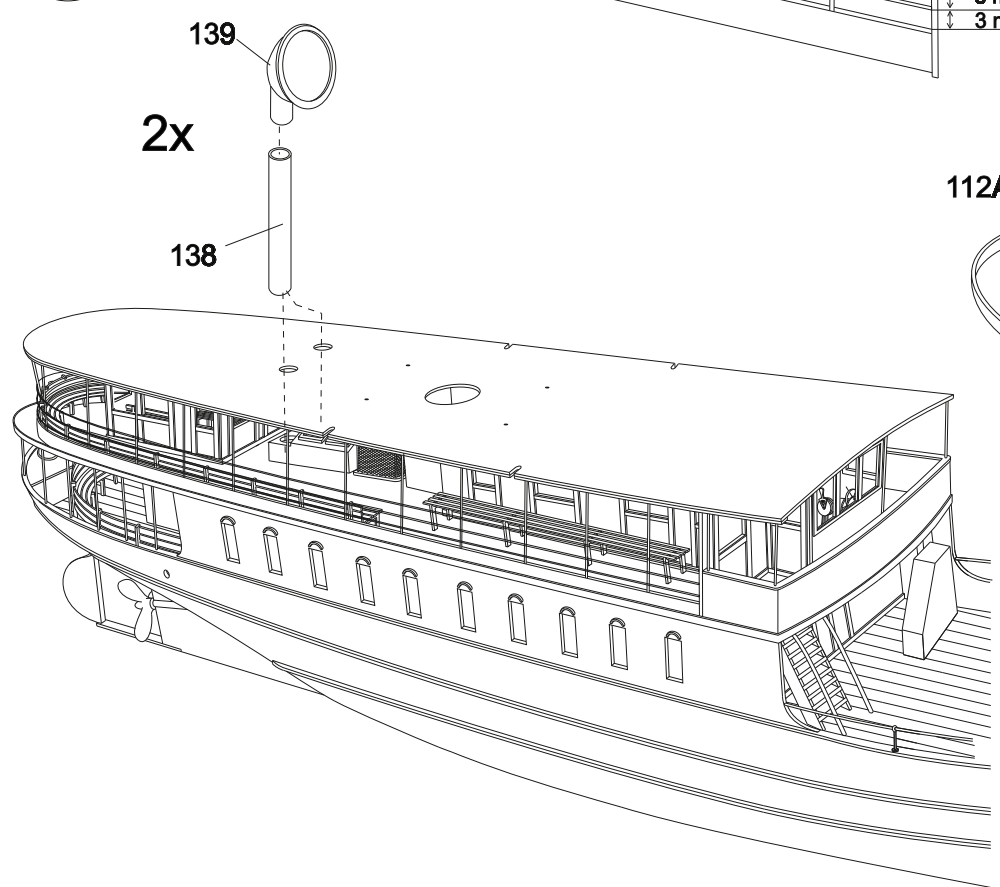

44

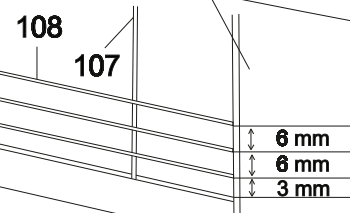
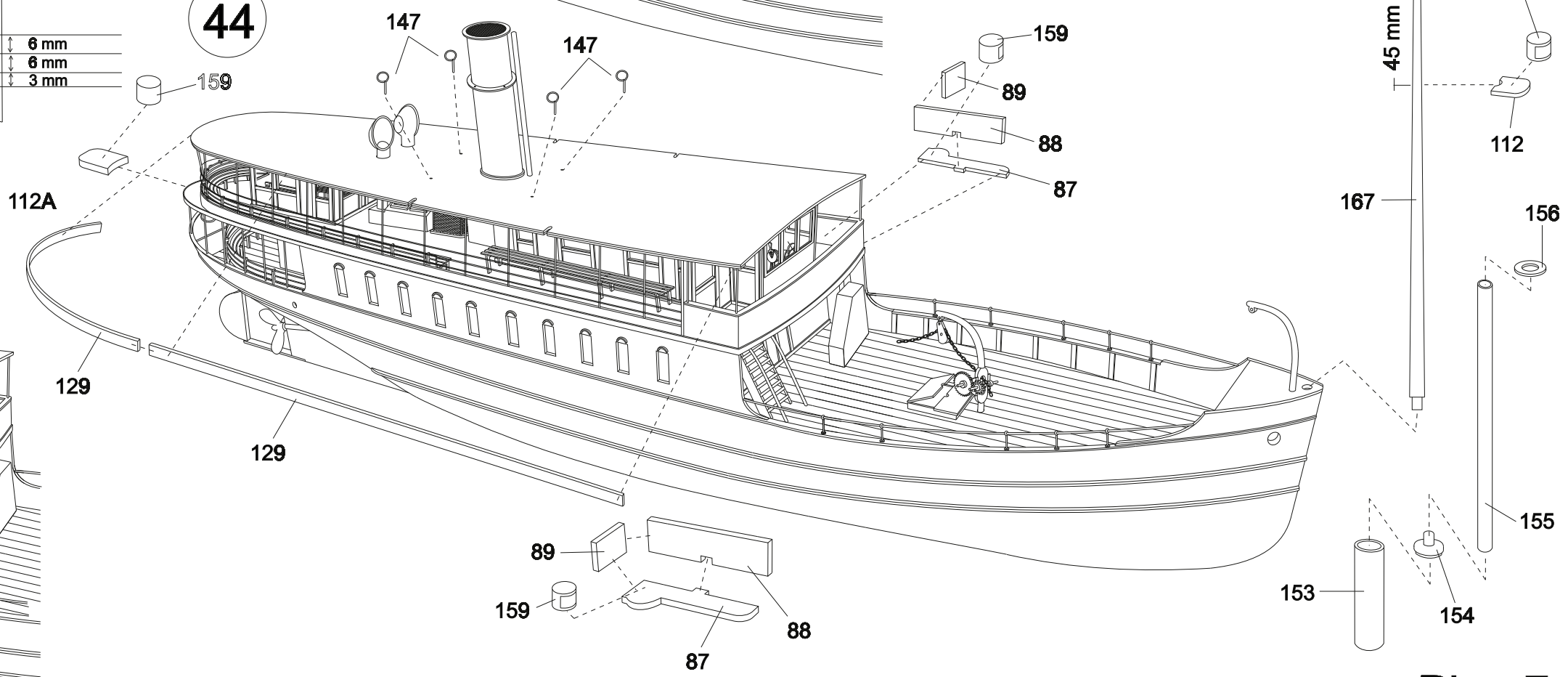

8x



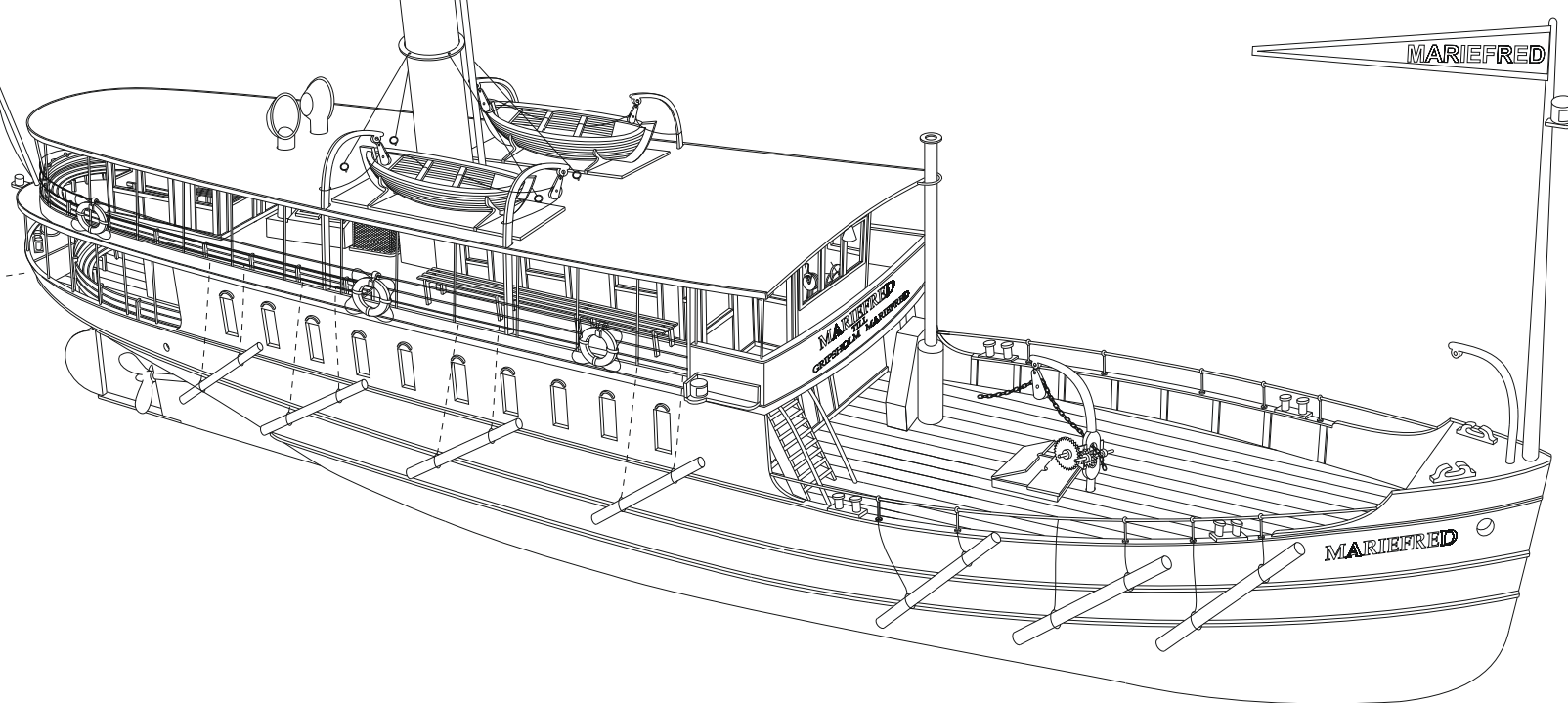
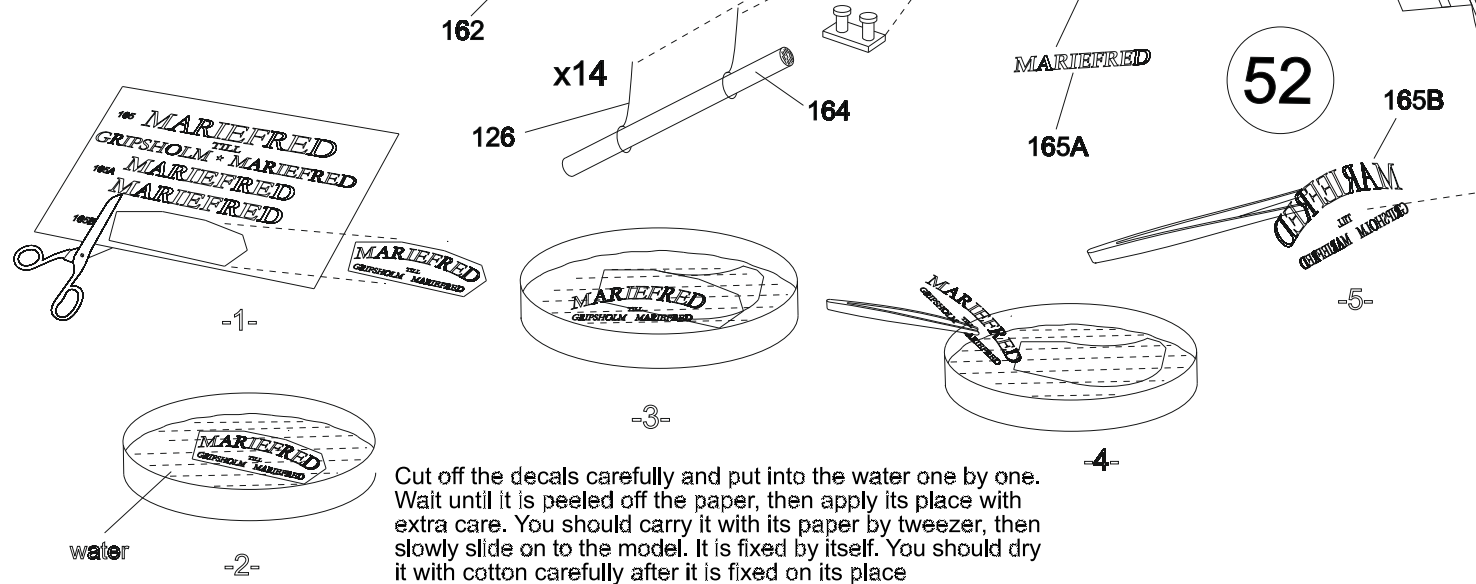
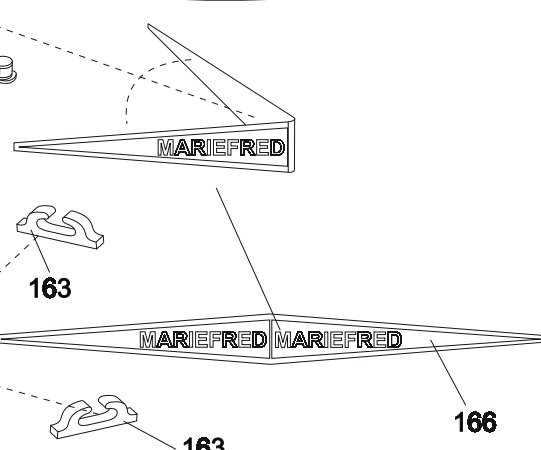
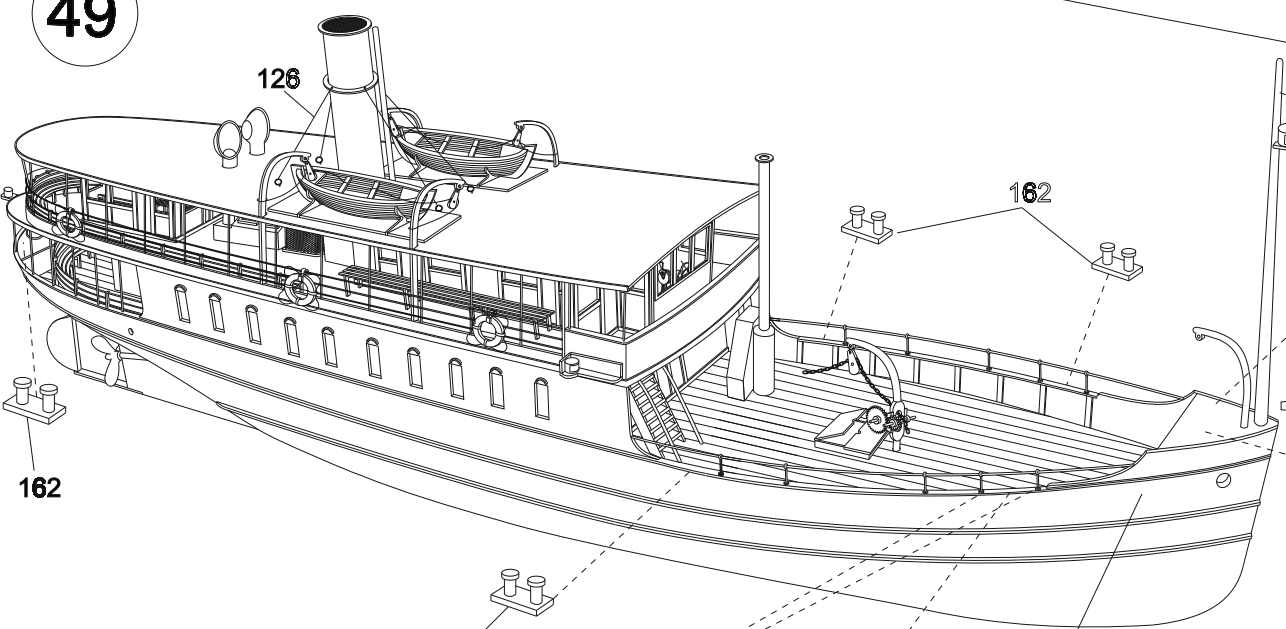
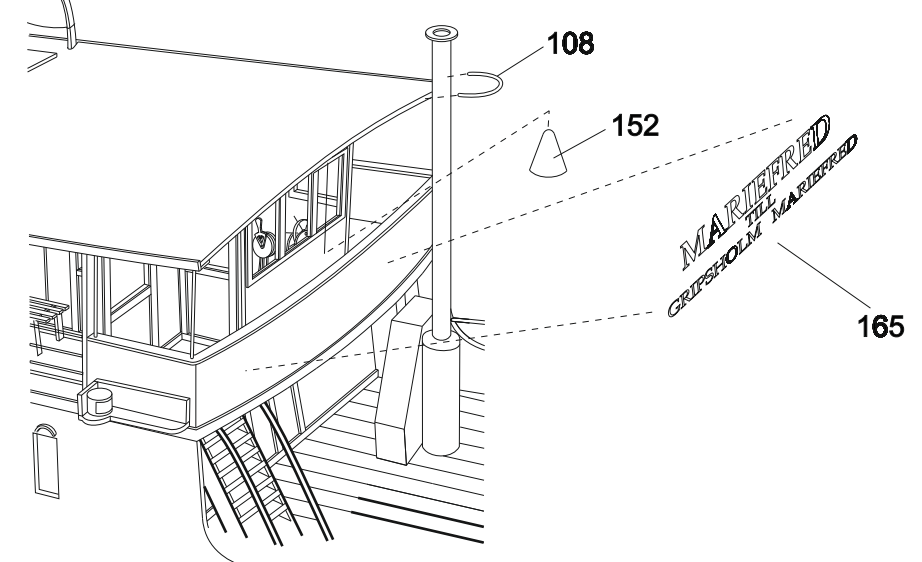
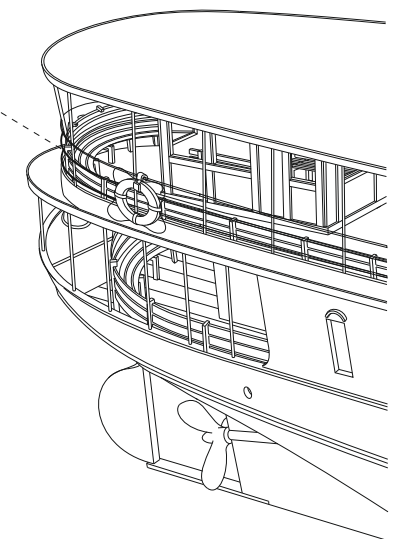
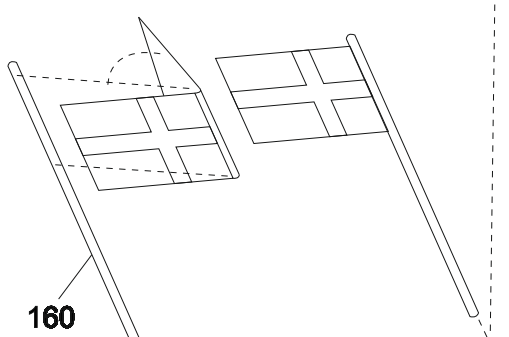
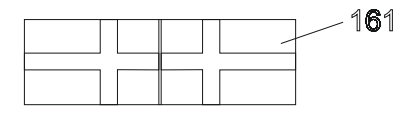
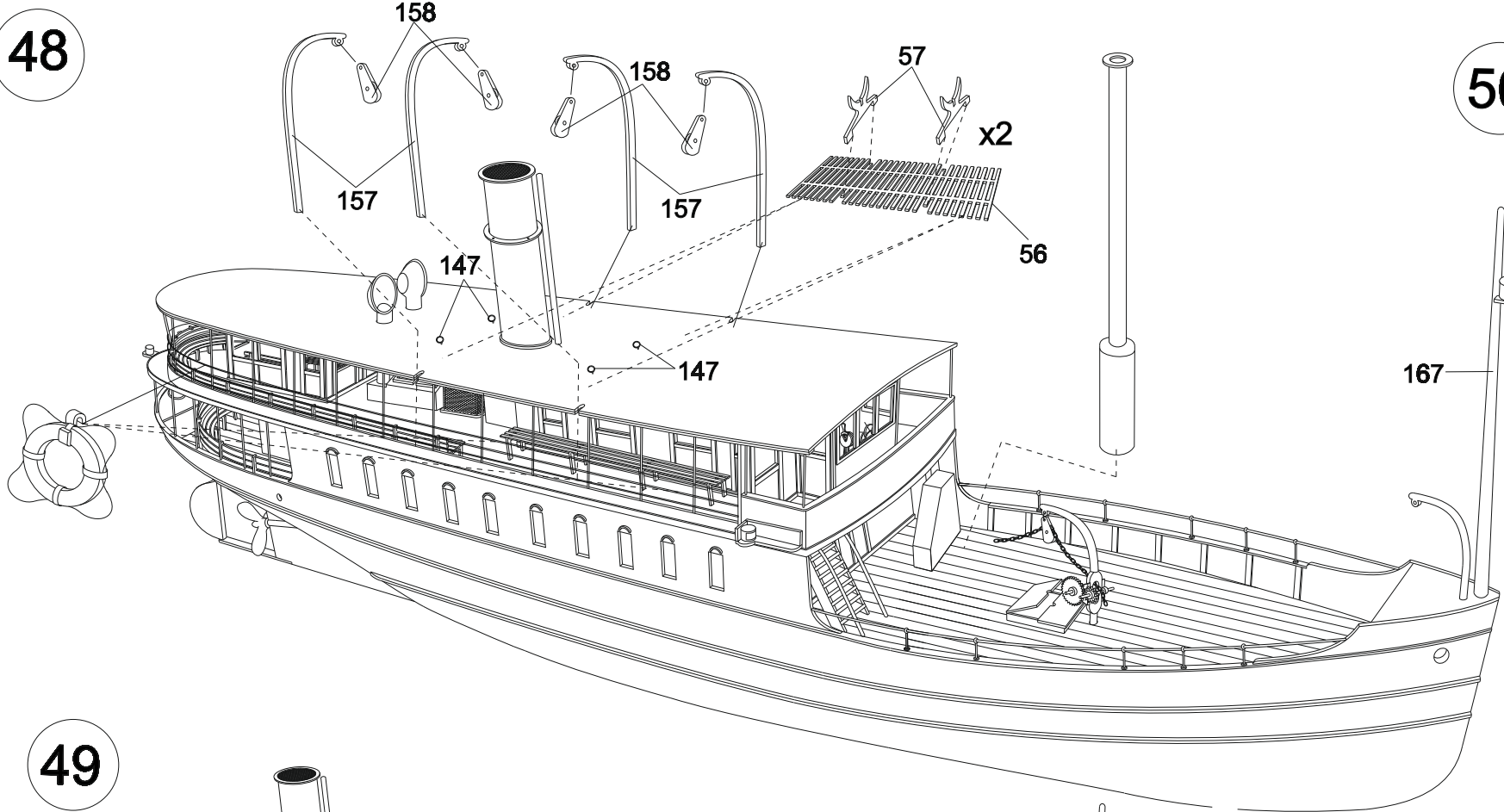

Cut off the decals carefully and put into the water one by one. Wait until it is peeled off the paper, then apply its place with extra care. You should carry it with its paper by tweezers, then slowly slide on to the model. It is fixed by itself. You should dry it with cotton carefully after it is fixed on its place



MARIEFRED PART LIST

NO	DESCRIPTION	SIZE	PART TYPE	QUANTITY
1-2-3	Keels	4 mm	Plywood	3
4 ... 17	Frames	4 mm	Plywood	16
18	Keel immobilizer parts	4 mm	Plywood	8
19	Back deck	1,3 mm	Plywood	1
20	Front deck	1,3 mm	Plywood	1
21	Bottom cabine front wall	1,3 mm	Plywood	1
22	Bottom cabine back wall	1,3 mm	Plywood	1
23-24	Back deck parts	1,3 mm	Plywood	2
25	Bottom cabine side walls	1,3 mm	Plywood	2
26	Back rail	1,3 mm	Plywood	1
27	Front rails	1,3 mm	Plywood	2
28	Nose deck	1,3 mm	Plywood	1
29 ... 34	Back cabine parts	1,3 mm	Plywood	6
35 ... 40	Front cabinet parts	1,3 mm	Plywood	6
42	Rudder immobilizer bar	4x170 mm	Metal	1
43	Rudder	4 mm	Plywood	1
44-45-46	Base plate parts	4 mm	Plywood	4
47-48-49	Main hold parts	1,3 mm	Plywood	5
50-51-52	Front hold parts	1,3 mm	Plywood	5
53	Side rail top parts	1,3 mm	Plywood	2
54-55	Back rail top parts	1,3 mm	Plywood	3
56	Lifeboat platforms	1,3 mm	Plywood	2
57	Lifeboat base plates	1,3 mm	Plywood	4
58	Top deck	1,3 mm	Plywood	1
59-60	Top deck cabine side walls	1,3 mm	Plywood	2
61-62-63	Captain cabine parts	1,3 mm	Plywood	4
64 ... 67	Cabine parts	1,3 mm	Plywood	4
68 ... 71	Top deck back cabine parts	1,3 mm	Plywood	4
72 ... 77	Top deck roof windows parts	1,3 mm	Plywood	12
78-79-80	Top deck balcony parts	1,3 mm	Plywood	4
81	Step hole frame	1,3 mm	Plywood	1
82	Seat legs-with back supporters	1,3 mm	Plywood	44
83	Seat legs-without back supporters	1,3 mm	Plywood	10
84	Step railing bottom part	1,3 mm	Plywood	1
85	Step railing top part	1,3 mm	Plywood	1
86	Ventilations deep part	1,3 mm	Plywood	1
87-88-89	Board light parts	1,3 mm	Plywood	6
90-91-92	Seat parts	1,3 mm	Plywood	6
93	Top deck side rail parts	1,3 mm	Plywood	2
94	Top deck back rail part	1,3 mm	Plywood	1
95	Top deck vertical bar guide parts	1,3 mm	Plywood	2
96	Bottom deck vertical bar guide parts	1,3 mm	Plywood	2
98	Propeller main part	-	3D Print-out	1
99	Propeller pals	-	3D Print-out	3
100	Windows	-	Clear Sheet	1
101	Strip	1x2.2x500 mm	Baswood	40
102	Window brows	-	Plexyglass	20
103	Strip	1,5x1,5x500 mm	Baswood	12
104A	Step sides	4 mm	Plywood	2
104B	Step sides	4 mm	Plywood	2
105	Steps	1x4x500 mm	Baswood	1

MARIEFRED PART LIST

NO	DESCRIPTION	SIZE	PART TYPE	QUANTITY
106	Front rail vertical bars	-	3D Print-out	10
107	Railing bar-vertical	0,8x500 mm	Flat Wire	6
108	Railing bar-horizontal	0,5x5000 mm	Wire	1
109	Rudder wheel legs	1 mm	Plexyglass	2
110	Rudder wheel	-	3D Print-out	1
111	Folio	130x170 mm	Aluminium Folio	4
112-112A	Light bottom part	1 mm	Plexyglass	2
113	Top	1,3 mm	Plywood	1
114	Telegraph machine	-	3D Print-out	1
117	Winch hanger part	-	3D Print-out	2
119	Winch supporter parts	1 mm	Plexyglass	2
120	Winch large gear	1 mm	Plexyglass	1
121	Winch small gear	1 mm	Plexyglass	1
122	Winch single reel	1 mm	3D Print-out	1
123	Winch chain	500 mm	Metal	1
124	Winch bars immobilizers	1 mm	Plexyglass	4
125	Front hanger	-	3D Print-out	1
126	Docking supporter rope	2000 mm	Waxed rope	1
127	Stair wire mesh	40x150 mm	Metal Mesh	1
128	Funnel filter	40x40 mm	Metal Mesh	1
129	Top side edge parts	1x4x700 mm	Baswood	5
130	Deck cover strips	0,5x4x550 mm	Ayous	40
131	Shaft pipe	6x100 mm	Metal pipe	1
132	Body planking strips	1,6x5x500 mm	Ayous	104
133	Giant bollard	-	Wooden	1
134 ... 137	Wheel chain bed parts	-	3D Print-out	6
138	Ventilation parts	10x60 mm	Metal	2
139	Ventilation	-	3D Print-out	2
142	Funnel bottom part	-	3D Print-out	1
143	Funnel	30x135 mm	Metal pipe	1
144	Funnel ring	1 mm	Plexyglass	1
145	Funnel lid	-	3D Print-out	1
146	Funnel front part	3x135 mm	Metal stick	1
147	Eyebolts	-	Metal	8
148	Life rings	-	3D Print-out	8
151	Life ring hangers	1 mm	Plexyglass	8
152	Bell	-	3D Print-out	1
153	Front deck tiny funnel bottom side	10x50 mm	Metal pipe	1
154	Front deck tiny funnel bottom side connecting part	-	3D Print-out	1
155	Front deck tiny funnel	6x130 mm	Metal pipe	1
156	Front deck tiny funnel lid	-	3D Print-out	1
157	Lifeboat hangers	2 mm	Plexyglass	4
158	Single reels	-	3D Print-out	4
159	Board lights	-	3D Print-out	4
160	Flag post	2 mm	Metal	1
161	Flag	-	Sticker	1
162	Double-head bollard	-	3D Print-out	6
163	Fairlead	-	3D Print-out	2
164	Docking supporters	4x60 mm	Dovel strip	14
165-A-B	Ship name and logos	-	Decal	4
166	Pennant	-	Sticker	1
167	Front post	230 mm	Dovel stick	1
168	Frame immobilizer parts	4 mm	Plywood	2
169	Rudder axle house	4 mm	Plywood	1



## ASISTANT GUIDE

- ❖ Please read the instructions carefully before you start to build your model. Take notes if needed. So, you may find out the materials and the tools those you need.
- ❖ Use model knife to take out the parts the plywood sheets. Do not take them out with hand!
- ❖ Change of temperature effects on plywoods quickly. So that, do not release the plywoods. Keep them on a flat surface by putting weight on them.
- ❖ You may stick together the wooden parts easily if you sand the brown areas caused by laser with sand paper.
- ❖ You should use super glue and white glue to stick together the wooden parts and use the super glue for metal parts.
- ❖ Building the keel of your model, before stick the frames, be sure the frames properly seated on the keel. Otherwise you can't build the body of the model rightly. Exactly be sure that left and right side of the frames are compatible and symmetrical.
- ❖ After building the keel of your model, before the covering, you should test the frame edges by a cover strip. You should sand with a piece of sandpaper the frame edges at the right degree to touch the strips on to the surface exactly. The curves are mostly the front and back side of the body.
- ❖ You should keep the strip tips in the bowl filled with water approximately one hour. So that you may curve the strips on the curves easily these are mostly at the end and the front of the hull.
- ❖ You should cover the strip starting from the top for each side symmetrically.
- ❖ You should cut the upper side of the strip when overlap occurs especially at the front curve of the body.
- ❖ To make equal the surface of the body that caused by planking, you should sand with a piece of sandpaper (Firstly you should use thick sandpaper, then you can apply thin sandpaper), . You should fill the gaps after this processing. You may use leftover strips for wide gaps and model putty for small gaps.
- ❖ If you don't want to appear wooden tissue of the body of your model body; first, apply filler undercoat then sand with a thin sandpaper to make it ready to apply putty. Apply putty whole body and sandpaper again. Apply one more coat filler undercoat and sandpaper. You should not use very thick sandpaper to sand the putty and filler undercoat. You should repeat this process until you get the results as you want. You should apply undercoat paint to find out if any mistake appears at the body. The body gets ready for painting after these applications. You may use model brushes for filler coating. In order to understand whether the materials (such paint, filler, undercoat, varnish, etc.) are compatible with each other, you should test on the unnecessary parts.
- ❖ Some of the model's logo, name or the number are produced from decal paper. You should keep them in a bowl filled with warm water for two or three minutes. You should apply them to their places while releasing from their paper. You may attach easily If you apply gloss varnish to the place before applying the decals. You may apply matt, gloss or satin varnish after this application preferably.
- ❖ You should keep your model away from direct sunlight, heat and moist to avoid deformation in the course of time.

- ❖ Maketinizin yapımına başlamadan önce planı ve plandaki yazıları dikkatlice gözden geçiriniz. Gerekli gördüğünüz yerlere notlar alınız. İhtiyacınız olan yardımcı malzeme ve aletleri de bu şekilde tespit edebilirsiniz.
- ❖ Kontraplak üzerindeki parçaları çıkartmak için mutlaka maket bıçağı kullanınız, el ile kopartmayınız!
- ❖ Kontraplaklar hava ısı ve neme karşı çok çabuk reaksiyon gösterirler. Bu yüzden modelin yapımı sırasında kontraplak parçaları serbest durumda bırakmayınız. Üzerine ağırlık koyarak düz bir satih üzerinde muhafaza ediniz.
- ❖ Maketin üretiminde kullanılan lazer kesimden kaynaklanan, ahşap üzerindeki kahverengi kısımları zımpara ile temizlerseniz daha iyi yapışmasını sağlarsınız.
- ❖ Ahşap parçaları yapıştırmak için beyaz ağaç tutkalı ve hızlı yapıştırıcı, metal parçalar için de hızlı yapıştırıcı kullanabilirsiniz.
- ❖ Maketin iskeletini oluştururken postaların omurga üzerine tam ve doğru bir biçimde oturduğundan emin olmadan yapıştırmayınız. Aksi halde gövdeyi düzgün bir şekilde oluşturamazsınız. Postaların birbirleri ile uyumlu bir şekilde sağ ve sol taraflarının simetrik olarak oturduğundan kesinlikle emin olunuz.
- ❖ Omurga iskeletini oluşturduktan sonra, çıta sarma işlemine geçmeden önce, posta kenarlarını bir sarma çitası ile prova edip, sarma çitasının özellikle maketin kavis alan ön ve arka kısımlarına doğru posta kenarlarının yüzeyine tam olarak temas etmesini sağlamak için uygun açıda zımparalayınız.
- ❖ Maketin gövde kısmını oluşturmak için çitaları postalar üzerine sarma işlemine başlamadan önce çitaları su dolu bir kapta bir saat kadar tutunuz. Böylelikle sarma işlemi yaparken uç kısımlara doğru artan kavisleri rahatlıkla dönebilirsiniz.
- ❖ Sarma çitalarını her defasında sağ ve sol taraftan birer kez simetrik olarak üstten başlayarak sarınız. Sarma çitaları özellikle ön kısımda birbirlerinin üzerine binmeye başladıklarında üst kısımlarından tıraşlayarak inceltiniz.
- ❖ Sarma işlemi bittikten sonra öncelikle kalın ve ince zımpara ile yüzeyini çitalardan kaynaklı taşmaları düzeltmek için zımparalayınız. Bu işlemden sonra, gövdede oluşan boşluklar var ise; büyük boşlukları atık çitalara şekil vererek, daha küçük boşlukları da dolgu malzemeleri ile kapatınız.
- ❖ Maketin gövdesinde ahşap doku izleri görünmemesi gerekiyorsa; önce dolgu astarı ardından ince bir zımpara ile zımparalayarak gövdenin tamamını macun çekmeye hazır hale getiriniz ve gövdeye macun çekip tekrar zımparalayınız. Üzerine bir kat daha dolgu astarı atarak tekrar zımparalayınız. Dolgu astarı ve macunu zımparalarken çok kalın zımpara kullanmayınız. Gövde istediğiniz gibi olana kadar bu işlemleri tekrarlayınız. Kusur olup olmadığını anlamak için en son olarak astar boya atınız. Ondandır gövde boyanmaya hazır hale gelmiştir. Dolgu astarını fırça ile atabilirsiniz. Kullanacağınız kimyasal içeren maddelerin ( boya, vernik, dolgu macunu, astar boya, vs. gibi ) birbiri ile uyuşup uyuşmadığını anlamak için ayrı bir yerde deneme yapınız.
- ❖ Modellerin üzerindeki logo, isim ya da numaraların bazıları suda çözünen çıkartmalardan üretilmektedir. Bunları çok küçük bir kabın içindeki ılık suda iki-üç dakika bekleterek kağıtlarından ayrılmasını sağlayıp dikkatli bir biçimde uygulanacağı bölgeye yerleştirebilirsiniz. Uygulanacak bölge temiz olmalı. Uygulamadan önce bölgeye parlak vernik atarsanız çıkartmanın çok daha iyi tutmasını sağlarsınız. Daha sonra tekrar üzerine tercihinize göre mat, parlak ya da saten vernik atabilirsiniz.
- ❖ Bitmiş modelinizi zamanla deforme olmaması için güneş ışığı, sıcaklık ve rutubet gibi etkenlerden uzak bir yerde sergileyiniz.